



**GENERAL GEOLOGY AND STRUCTURAL  
ANALYSIS OF GUNUNG AYAM, LOJING,  
KELANTAN**

by

**AHMAD BUKHARI BIN HAZMEE**

A report submitted in fulfillment of the requirement for the degree of  
Bachelor of Applied Science (Geoscience) with Honours

---

**FACULTY OF EARTH SCIENCE  
UNIVERSITI MALAYSIA KELANTAN**

2017

## DECLARATION

I declare that this thesis entitled “General Geology and The Structural Analysis of Gunung Ayam, Lojing, Kelantan” is the result of my own research except as cited in the references. The thesis has not been accepted for any degree and is not concurrently submitted in candidature of any other degree.

Signature : \_\_\_\_\_  
Name : \_\_\_\_\_  
Date : \_\_\_\_\_

UNIVERSITI  
MALAYSIA  
KELANTAN

## ACKNOWLEDGEMENT

*In the name of Allah, the Most Graceful and the Most Merciful.*

*All the praises and thanks be to Allah, the Lord of the 'Alamin, The Most Gracious, The Most Merciful. The only owner of the day of Recompense, You (Alone) we worship and You (Alone) we ask for help, Guide us to the straightway, The way of those on whom You have bestowed Your grace, Not of those who earned Your anger, Nor of those who went astray" (Al-Fatihah, 1:1-7)*

First of all, Alhamdulillah all praise is to Allah. Thanks to Allah SWT because with his permission, I able to complete the research my first thesis entitled **“General Geology and The Structural Analysis of Gunung Ayam, Lojing, Kelantan”** within the given time. During the completion of this thesis, it had gave a lot of new knowledge and experiences that are very useful for me to use in the future.

I would like to express my gratefulness to the authority of Universiti Malaysia Kelantan (UMK) and Faculty Of Earth Science (FSB) for all the facilities and equipment provided during this research is conducted. I'm also thanking to the staffs of UMK that helps in smoothing things around.

Furthermore, I would like to thank to the Head of Department Geoscience, Ir. Arham Muchtar Achmad Bahar, my supervisor, Mr. Mohd Syakir Sulaiman, and my examiners Dr. Mohammad Muqtada Ali Khan, Mdm 'Ainaa' Mardhiyah Binti Hassin and Miss Zakiyah Binti Ainul Kamal who gives a lot of useful guidance, advice, knowledge and information through their comments and views.

Next, I would like to acknowledge my parent, Mr. Hazmee Bin Abd. Halim and my mother, Mdm. Tahirah Binti Abdullah for their moral and financial support during this thesis writing and all the time.

Special thanks to my colleagues Mohd Zaki Bin Zulkifli, Siti Saadiah Binti Abdul Latiff, Nur Liyana and Dafye Tony Payah and my juniors

Nurzulaikha Najihah binti Mazahar, Siti Nur Khalidah Binti Husairy and Nadzirah Khalisah Binti Mohd Zakari for their contribution of ideas and motivation to keep me writing this thesis.

Lastly, I would like to express my utmost gratitude to all my brothers, lecturers and friends that have involved whether directly or indirectly towards the compilation of this thesis. Any errors, of course, is entirely my fault. I end this note by apologizing for all those errors.

Ahmad Bukhari Bin Hazmee

UNIVERSITI  
MALAYSIA  
KELANTAN

# GENERAL GEOLOGY AND STRUCTURAL ANALYSIS OF GUNUNG AYAM, LOJING, KELANTAN

## ABSTRACT

The study area is located at Gunung Ayam area in Lojing district in Kelantan state with coordinates ( N 04° 48' 30'' , E 101° 46' 30'' ), ( N 04° 46' 0'' , E 101° 46' 30'' ), ( N 04° 46' 0'' , E 101° 44' 0'' ) and ( N 04° 48' 30'' , E 101° 44' 0'' ). The study area consist of carbonate rock, meta-sediment and siliciclastic rock under Gua Musang Formation. This study focus on the update of the geological map of study area with scale 1: 25 000 and the structural analysis in study area. In order to fulfil the objectives of this research, a few methods had been choose which are doing field work activities and laboratory work by using petro-thin for thin section purpose. In order to gather the data regarding study area, several site visits and fieldworks had been conducted. From the result of structural analysis, main force that acting on the study area is came from the Northern part of the study area. The Gunung Ayam area also had a lot of interesting geological features such as Karst topography and conglomerate, making this area is suitable for geoheritage site in the future.

Keywords : Gunung Ayam, conglomerate, structural analysis, Gua Musang formation.

UNIVERSITI  
MALAYSIA  
KELANTAN

# **GEOLOGI UMUM DAN ANALISA STRUKTUR DI KAWASAN GUNUNG AYAM, LOJING, KELANTAN**

## **ABSTRAK**

Kawasan kajian terletak di kawasan sekitar Gunung Ayam di daerah Lojing di antara (N 04° 48' 30'', E 101° 46' 30''), (N 04° 46' 0'', E 101° 46' 30''), (N 04° 46' 0'', E 101° 44' 0'') dan (N 04° 48' 30'', E 101° 44' 0'') di negeri Kelantan Darul Naim. Kawasan kajian terdiri daripada batuan karbonat, meta sedimen, dan batuan silisiklastik di bawah formasi Gua Musang. Kajian ini tertumpu kepada penghasilan peta geologi dengan skala 1: 25 000 dan untuk mengkaji struktur-struktur yang berlaku dikawasan kajian. Untuk memenuhi objektif-objektif tersebut, beberapa kaedah telah digunakan seperti kerja lapangan dan petrografi keratan nipis. Untuk menghasilkan peta geologi kawasan kajian, kerja lapangan dilakukan untuk mengumpul data. Keputusan menunjukkan arah daya yang paling besar di kawasan sekitar Gunung Ayam datang dari arah Utara. Kawasan Gunung Ayam mempunyai banyak tarikan geologi seperti topografi kast dan batuan conglomerat yang membuatkan kawasan ini sangat sesuai untuk dijadikan tapak geowarisan di masa hadapan.

Kata kunci : Gunung Ayam, conglomerat, analisa struktur, formasi Gua Musang.

UNIVERSITI  
MALAYSIA  
KELANTAN

## TABLE OF CONTENTS

TITLE	PAGE
<b>THESIS DECLARATION</b>	<b>i</b>
<b>ACKNOWLEDGEMENT</b>	<b>ii</b>
<b>ABSTRACT</b>	<b>iv</b>
<b>TABLE OF CONTENTS</b>	<b>vi</b>
<b>LIST OF TABLES</b>	<b>ix</b>
<b>LIST OF FIGURES</b>	<b>x</b>
<b>LIST OF MAPS</b>	<b>xiv</b>
<b>LIST OF ABBREVIATION</b>	<b>xv</b>
<b>LIST OF SYMBOLS</b>	<b>xvi</b>
<b>CHAPTER 1 : INTRODUCTION</b>	
1.1 General Background	1
1.2 Problem Statement	3
1.3 The Objectives of Research	3
1.4 Study Area	4
1.5 Geography of Gua Musang	8
1.5.1 People Distribution	8
1.5.2 Rain Distribution	9
1.5.3 Land used	11
1.5.4 Social Economy	13
1.5.5 Road Connection	15
1.6 Scope of The Study	18
1.7 Significance of Research	18
1.8 Chapter's Summary	18
<b>CHAPTER 2 : LITERATURE REVIEW</b>	
2.1 Introduction	20
2.2 Regional Geology of Kelantan	20
2.3 Formation in Gua Musang	21
2.4 Stratigraphy	22
2.5 Structural Geology	25
2.5.1 Brittle Deformation	31
2.5.2 Joints and Veins	32

2.5.3 Faults	36
2.5.4 Ductile Deformation (Fold)	40
<b>CHAPTER 3 : MATERIALS AND METHODS</b>	
3.1 Introduction	44
3.2 Preliminary Researches	44
3.3 Materials	48
3.4 Field Studies	58
3.5 Laboratory Investigation	60
3.6 Data Analysis and Interpretation	66
3.7 Report Writing	67
<b>CHAPTER 4 : GENERAL GEOLOGY</b>	
4.1 Introduction	68
4.2 Geomorphology	70
4.2.1 Topography	70
4.2.2 Drainage System	78
4.2.3 Weathering Process	84
Physical Weathering	87
Chemical Weathering	88
Biological Weathering	89
4.2.4 Mass Movement	90
Erosion	90
Rock Fall	92
4.3 Field Observation and Mapping	93
4.4 Lithology and Stratigraphy	95
4.3.1 Limestone	96
4.3.2 Sandstone	100
4.3.3 Conglomerate and Breccia	103
4.5 Structural Geology	107
4.5.1 Lineament	109
4.6 Historical Geology	113
<b>CHAPTER 5 : STRUCTURAL ANALYSIS</b>	
5.1 Introduction	116



5.2 Fold Analysis	116
5.3 Fault Analysis	119
5.4 Joint Analysis	122
5.5 Lineament Analysis in Study Area	126
5.6 Bedding Analysis	130
<b>CHAPTER 6 : CONCLUSION AND RECOMMENDATION</b>	
6.1 Introduction	132
6.2 Conclusion	132
6.3 Recommendation	133
<b>REFERENCES</b>	134

## LIST OF TABLES

NO.	TITLE	PAGE
1.5.1	People Distribution of Gua Musang	8
1.5.2	Total rain distribution in Gua Musang	9
1.5.3	Land use of Kelantan	11
1.5.4	Industrial activities of Gua Musang	13
2.1	Some commonly used terms that are related to stratification	29
2.2	Terms used to describe types of bedding	30
2.3	Joint Terminology	33
2.4	The classification of brittle fault rock	39
3.1	Comparison between Quadrant bearing and Azimuth bearing	50
3.2	The instruments and tools that needed for field work	52
3.3	The flow for thin section processes	62
4.1	The topographic unit based on elevations	72
4.2	Weathering grade classification	85
4.3	Description of limestone thin section of study area	98
4.4	Description of fine grain sandstone thin section of study area	102
4.5	The strike data for the lineament from the regional terrain map	111
5.1	The joint orientation data	123
5.2	Data strike for lineament in study area	126
5.3	The strike and dip measurement for bedding outcrop	130

## LIST OF FIGURES

NO.	TITLE	PAGE
1.1	Terrain Image of study area from satellite	7
1.2	Earth's image from satellite	7
1.3	The average rainfall for Gua Musang	10
1.4	The average temperature for Gua Musang	10
1.5	Land use for palm estate.	12
1.6	The forest and palm plantation area	12
1.7	Grocery shop and residential area in study area	14
1.8	Rubber estate owned by residents in the study area	14
1.9	Unpaved road in study area	15
1.10	The paved road in study area	16
1.11	Bridge at Sg. Berok connecting Pos Blau	16
2.1	Geological map that shows the distribution of rocks in Kelantan state	24
2.2	(a) Disconformity, (b) Angular unconformity	27
2.3	(c) Nonconformity, (d) Buttress unconformity	27
2.4	Features used to identify unconformities : (a) scour channels in sediments, (b) basal conglomerate, (c) age discordance from fossil evidence and (d) paleosol	28
2.5	Types of brittle deformation	32
2.6	(a) Block diagram showing the various components of an ideal plumose structure on a joint. The face of joints 1 is exposed while joint 2 is within the rock (b) Block diagram showing the occurrence of both systematic and non-systematic joints in a body of rock	34
2.7	(a) Formation of joints in the hanging-wall block of a region of normal faulting. (b) Formation of joints above an irregularity in a reverse fault surface. (c) The occurrence of pinnate joints along a fault	35

2.8	The types of vein arrays. Vein fill is dark (a) Planar array of veins. (b) Stockwork array of veins	36
2.9	Sketches illustrating differences between faults, fault zones and shear zone. (a) Fault. (b) Fault zone, with cataclastic deformation adjacent to the fault surface. (c) Sketch illustrating the relation between fault and fault splay. (d) shows the anastomosing faults in a fault zone. (e) a shear zone, the displacements are shown to intersect the ground surface whereas the shear zone occurs at depth in the crust	37
2.10	The block diagram sketches showing the different types of fault	38
2.11	Anderson's theory of faulting predicts. (a) normal fault. (b) reverse fault or thrust faults. (c) strike-slip faults	40
2.12	The terminology of a fold	41
2.13	(a) The anticline, an upward facing synform. (b) The fold is syncline, the downward facing antiform. Younging direction is indicated by $\bigcirc \rightarrow$ arrow	42
2.14	The anticlinal and synclinal overturned folds. Younging direction is indicated by $\bigcirc \rightarrow$ arrow	43
2.15	An example of regional-scale superposed folding. (a) Recumbent, isoclinal anticline, of pre-Jurassic age. (b) Antiformal and synformal folding of the recumbent, isoclinal anticline.	43
3.1	The research flow chart	47
3.2	Suggested way to use a Brunton compass	49
3.3	The Petro-cut machine	64
3.4	The PetroTrim, machine	64
3.5	The Petro-thin machine	65
3.6	The thin section viewer	65
4.1	The cascade area at the valley	73
4.2	Hills and valley in the study area	73

4.3	The mountain area, which is Gunung Ayam	74
4.4	Fluvial area in palm estate	74
4.5	Type of drainage pattern	79
4.6	The main river in study area, Sg. Berok	80
4.7	The small stream that has clear water in study area	81
4.8	The presence of cascade in study area	81
4.9	Physical weathering on tuff outcrop	87
4.10	Chemical weathering on limestone outcrop forming pinnacles structures and fractures.	88
4.11	Biological weathering on sandstone outcrop, as root from vegetation make crack on outcrop.	89
4.12	Rill erosion.	91
4.13	Sheet erosion on hill in study area	91
4.14	The occurrence of rock fall on sandstone outcrop besides main road in study area.	92
4.15	Hand specimen of coarse grain limestone.	97
4.16	Hand specimen of limestone with calcite vein.	97
4.17	The thin section for limestone, that contain, calcite vein	98
4.18	The limestone outcrop that located in banana tree and palm estate.	99
4.19	The bedded limestone at the fluvial area in palm estate with hammer and person as scale.	99
4.20	The coarse grain sandstone interbedded with shale ( dark grey ), there can be observe structure features such as open folds, drag fold and reverse fault with geological hammer and people as scale.	101
4.21	The hand specimen for medium to fine grain sandstone, with changes of colour due to weathering.	101
4.22	Thin section of sandstone viewed under 4x magnification showing a small grain of quartz.	102
4.23	The hand specimen of conglomerate with pen as scale.	103

4.24	The conglomerate with clasts range from 5 mm to 30 mm, GPS act as scale	104
4.25	The conglomerate outcrop at foot of Gunung Ayam near waterfall with clasts range from 50 mm to 500 mm, people as scale.	104
4.26	The stratigraphic unit.	106
4.27	(a) The regional terrain map of the study area. (b) The lineament map of the study area.	110
4.28	Rose diagram of regional lineament.	112
4.29	Cartoon showing the tectonic evolution of Sundaland (Thailand–Malay Peninsula) and evolution of the Sukhothai Arc System during Late Carboniferous–Early Jurassic times	114
4.30	The depositional environments of sedimentary rocks is study area	115
5.1	The open fold with only half limb at sandstone interbedded with shale outcrop.	117
5.2	The stereonet for open fold with only half limb at the sandstone interbedded with shale outcrop.	118
5.3	The stereonet for bed at the sandstone interbedded with shale outcrop.	118
5.4	The appearance of normal fault at roadside.	120
5.5	The reverse fault at tuffaceous outcrop.	121
5.6	The shear and extensional joint on sandstone outcrop.	122
5.7	The rose diagram showing direction of main force.	125
5.8	The rose diagram for lineament in study area.	128
5.9	The Stereonet plot for bedding analysis.	131

## LIST OF MAPS

NO.	TITLE	PAGE
1.1	Map showing research area which is located in Lojing, Kelantan.	5
1.2	Map showing base map of research area.	6
1.3	The road connection within study area.	17
4.1	The contour map for study area.	75
4.2	3 D map of study area.	76
4.3	The landform map of study area.	77
4.4	The drainage pattern of study area.	82
4.5	The watershed of study area.	83
4.6	Traverse Map of Gunung Ayam, Lojing, Kelantan.	94
4.7	The Geological map of study area with observation points.	105
5.1	The lineament map of study area.	129

## LIST OF ABBREVIATIONS

Af	Tropical rain forest climate
E	East
ENE	East-North-East
ESE	East-South-East
ft	feet
GPS	Global Positioning System
Kg.	Kampung
km	Kilometre
m	Metre
cm	Centimetre
mm	Millimetre
km <sup>2</sup>	Kilometre square
Max	Maximum
Min	Minimum
N	North
NW	Northwest
SE	Southeast
Sg.	Sungai
WNW	West-North-West
WSW	West-South-West



## LIST OF SYMBOLS

°	Degree
%	Percentage
°C	Degree Celsius
$\sigma$	Stress



UNIVERSITI  
MALAYSIA  
KELANTAN

# CHAPTER 1

## INTRODUCTION

### 1.1 General Background

This study is about general geology of Gunung Ayam, as well as structural analysis at study area. Geology is a study about the Earth, study about the composition, structural, physical properties and the history of Earth. The study area located at Lojing-Cameron Highland road numbered as Road 185. The population for the study area is low. Some part of study area consists of agriculture sites and some oil palm plantations. The study area is easy to access because present of Lojing-Cameron Highland highway. This road used by people because it connects Kelantan state with Cameron Highland. In the South-Eastern part of Kelantan, at the foot of the Central Titiwangsa Range, Lojing Highlands are the continuation of the Cameron Highlands. It has an altitude from 610 - 1 500 m above sea level. The logging trails were the main access roads into Gunung Ayam. The early settlers were started by the Temiars that lives beside Belatop's river and Brooke's river (also spelled as Berok's river). It was believed that the head of an Asli family, called Ajing was the first resident at Sungai Belatop. Later on, Lojing area was named after him, and Ajing then became Lojing. Besides that, in Lojing, the biggest flower in the world, Rafflesia (*Rafflesia kerrii*), known as Bunga Pakma, can be found. Rafflesia also act as the icon for the Lojing Highlands.

This study is about structure geology of study area which located at Gunung Ayam area. Structure geology is study about deformation process that takes place on a particular area due to tectonic activity. The deformation process can be folding, faulting, fracturing on country rock.

In this research, there are chapter 1, chapter 2, chapter 3, chapter 4, chapter 5 and chapter 6. In this chapter one, brief information about the study area and the research that had been done in study area before this research take place will be provided. This chapter also present about the general geology of this study area followed by chapter two which contains literature review regarding this thesis. Chapter three will provide the information regarding the materials and methods that will be used to conduct this study, these including the tools, software and instruments needed to run this research. For chapter four, the general geology is presented with geomorphology, drainage pattern, lithology and stratigraphy, structural geology as well as the historical geology of the study area. Chapter five focus on the specification of the study which is structural analysis. Chapter six told about conclusion and recommendation for this research and future research.

## **1.2 Problem statement**

During previous study, the occurrence of landslide along Lojing-Cameron Highland highway, road no.185, keep rising in number as time passed. This research is conducted in order to study about structural pattern of study area. Besides that, geological data for study area is not update for a long of time. The resources for information and reading material for study area also limited. Furthermore, this study is an emphasis of previous or related in geology study.

## **1.3 Objectives of Research**

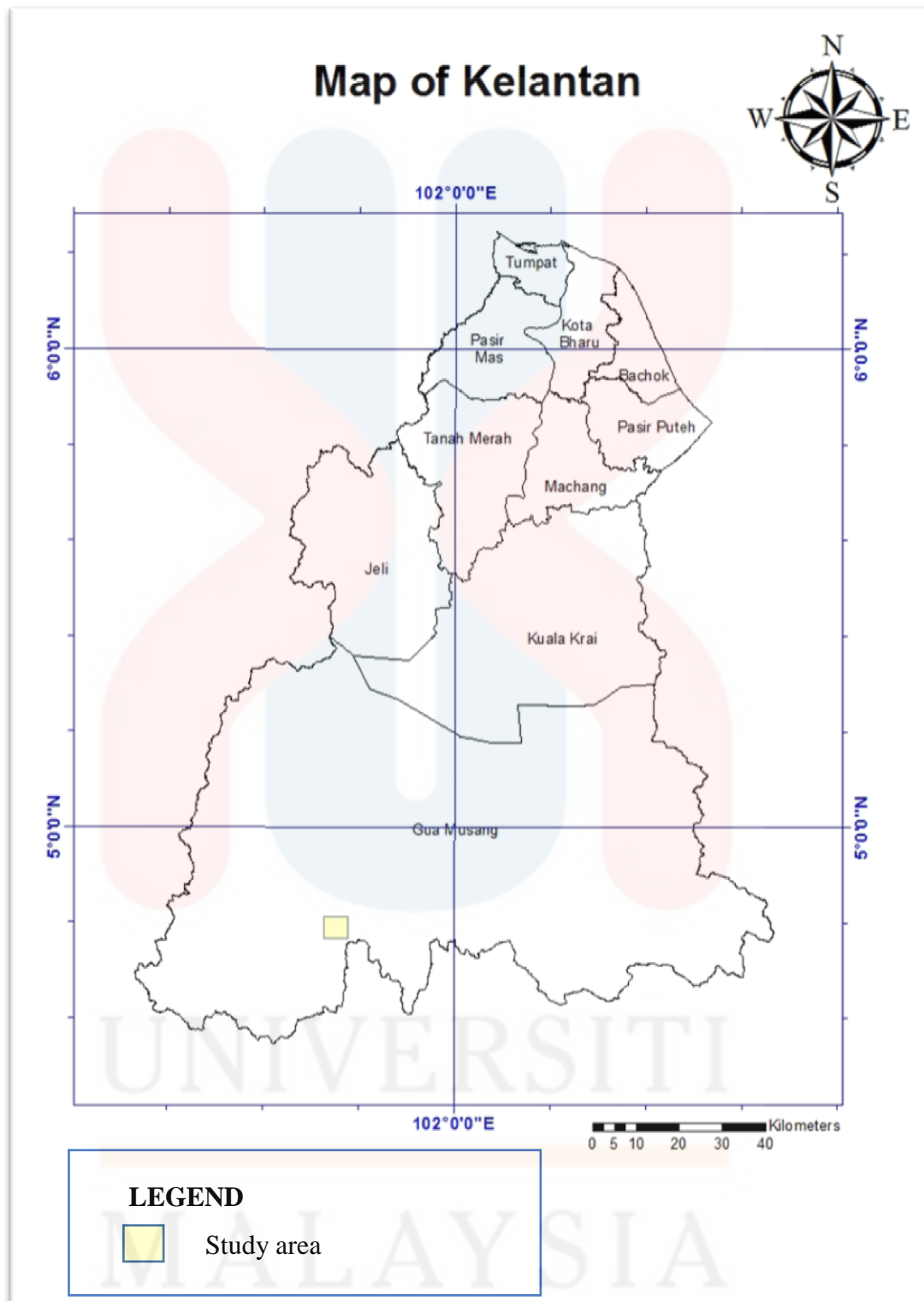
The geological mapping and structural analysis of Gunung Ayam area is done to fulfil the requirement to get Bachelor degree of Applied Science Geoscience as set by Faculty of Earth Science of University of Malaysia Kelantan. This writing is based on field study and lab studies. The objectives of this research are to:

1. To produce an update map of study area with scale 1:25 000.
2. To conduct structural analysis and relate it with deformation processes of study area.

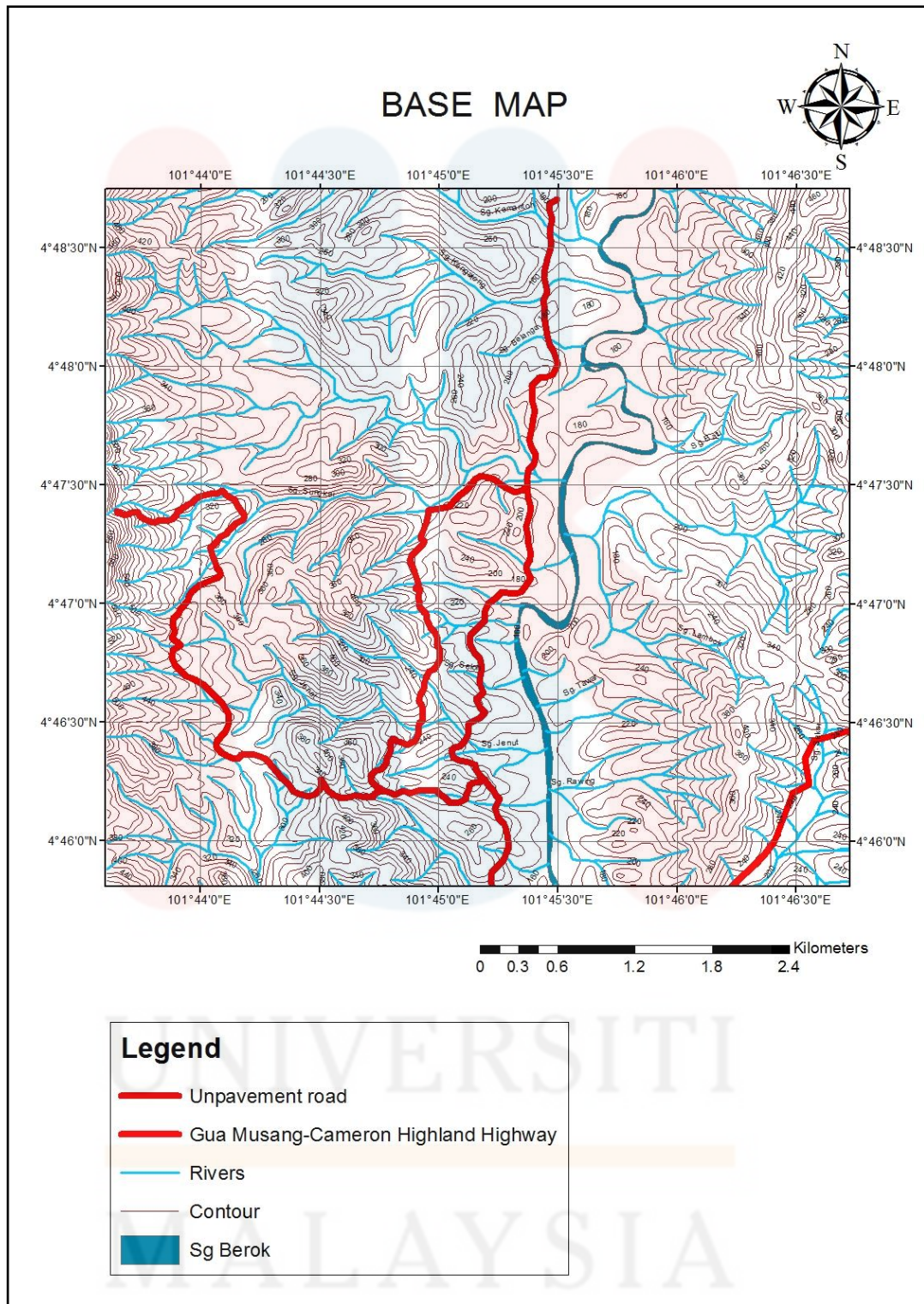
## 1.4 Study Area

The study area located at the Gunung Ayam and part of Lojing-Cameron Highland highway under district of Kelantan state, Gua Musang. The size for study area is around 25 km<sup>2</sup> including small portion of Gunung Ayam. It's located along border of Pahang state. The lithology of study area consist of conglomerate of Gunung Ayam, shale with subordinate of sandstone, limestone, tuff and marble. The vegetation of study area are oil palm plantation, rubber plantation and minor of rain forests. The geomorphology of study area are dominated by hills and mountains. One of the famous mountain in this area is Gunung Ayam, with the height of 4,934 ft (1,504 m) consist of conglomerate aged Permian to Triassic. The study area also made up of Gua Musang formation. Main river that flow within study area called Sg. Beruk (also spelled as Sg. Brook). The coordinate within study area are between ( N 04° 48' 30'', E 101° 46' 30'' ), ( N 04° 46' 0'', E 101° 46' 30'' ) , ( N 04° 46' 0'', E 101° 44' 0'' ) and ( N 04° 48' 30'', E 101° 44' 0'' ).

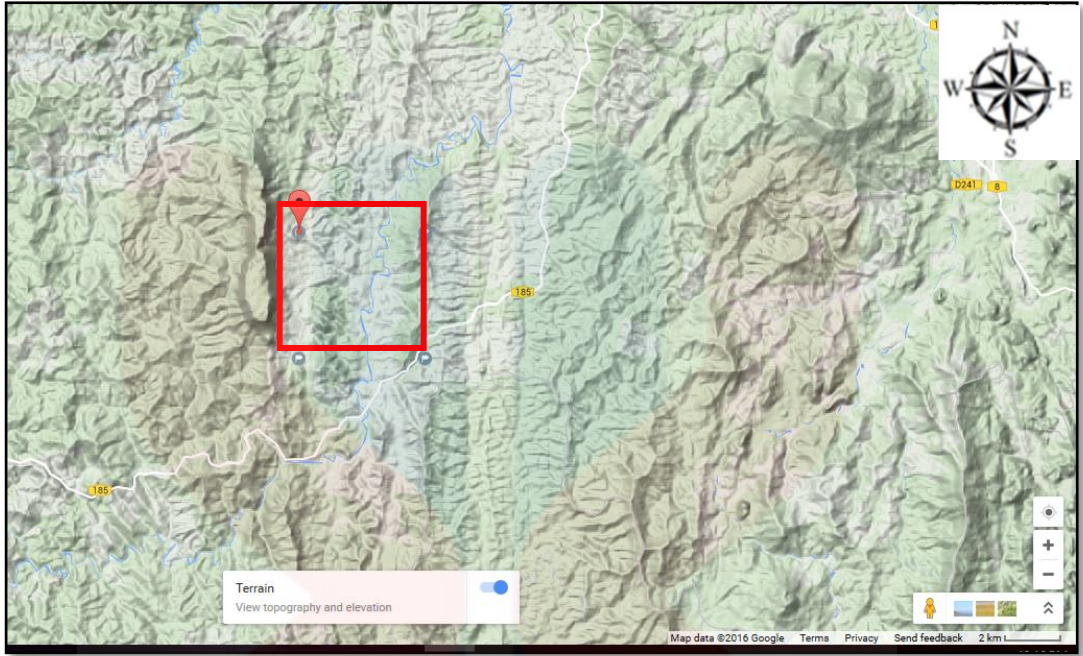
Map 1.1 showing the map of Kelantan and study area that located in Gua Musang district in Kelantan. Map 1.2 shows base map that had been produced using ArcGIS 10.3 software regarding study area. In figure 1.1, its shows regional contours and lineaments. By observing aerial photo, rock types in study area can roughly determined. Figure 1.2 shows aerial photo for study area. Its shows forests, rivers and plantations area within study area roughly.



**Map 1.1:** Map showing research area which is located in Lojing, Kelantan.



**Map 1.2:** Map showing base map of research area which is located in Lojing, Kelantan.



**Figure 1.1 :** The terrain image of study area (red box) from satellite. (source : Google maps, 2016)



**Figure 1.2 :** The Earth image from satellite for study area (red box). (Source : Google Earth, 2016)



## 1.5 Geography of Gua Musang

### 1.5.1 People Distribution

Based on Department of Statistic Malaysia, during 2010, total people that lived at Gua Musang district is 90,057 with dominant race is Malay, followed by Chinese, Indian and other races. On 2016, Gua Musang district has population of around 120,400 people. The percentage of Malay population is 76%, Chinese 5%, Indian 1%, Orang Asli 13%, and others (non-citizens) of 5%.

Gua Musang are divided into three district which are Bertam, Chiku and Galas. According to Majlis Daerah Gua Musang, people distribution in Gua Musang are divided based on Table 1.5.1.

**Table 1.5.1 : People distribution of Gua Musang**

District	People Distribution	Male	Female
Bertam	16 923	8 670	8 253
Chiku	26 251	11 908	11 908
Galas	31 814	16 769	15045

(Majlis Daerah Gua Musang, 2015)

### 1.5.2 Rain distribution

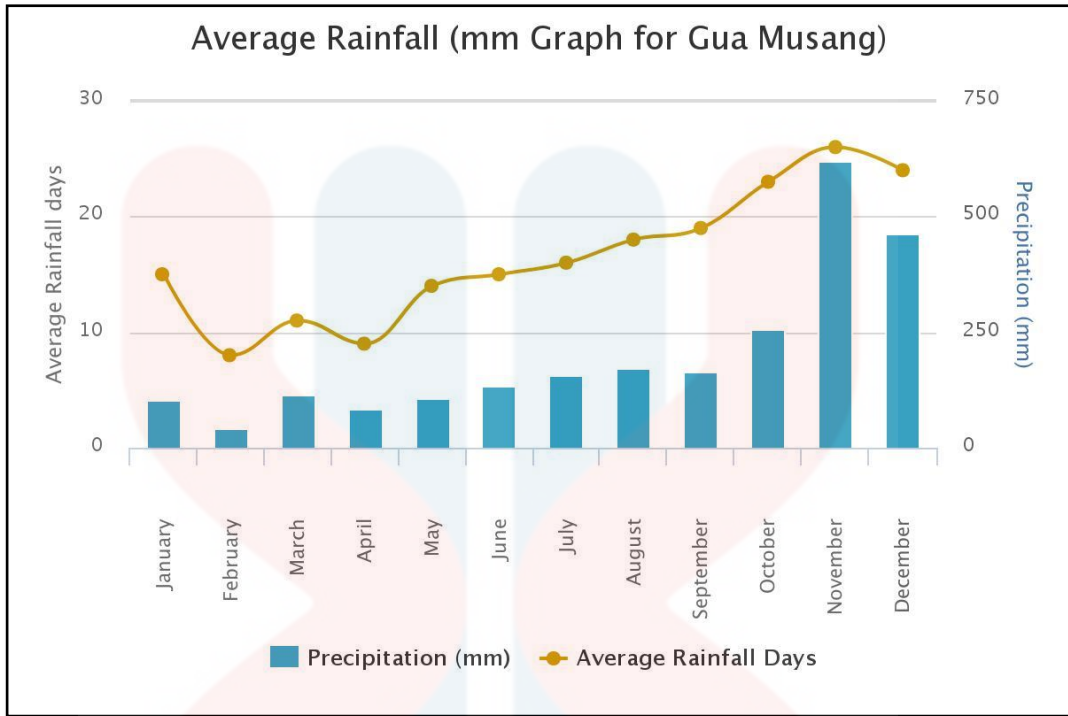
Gua Musang has tropical climate with rainfall regularly even during the driest month. According to Köppen–Geiger climate classification system, Gua Musang climate conditions is Af which is tropical rainforest climate. The total rainfall distribution in Gua Musang area is recorded by Kelantan meteorological department. Based on Table 1.5.2, the statistic of the rainfall distribution is measured from year 2011-2015. The highest value of total rainfall distribution was during 2014, with highest total rainfall distribution which is 2721.0 mm per month. In 2013, it shows the lowest rainfall distribution which is 1765.5 mm per month.

**Table 1.5.2** : Total rain distribution in Gua Musang

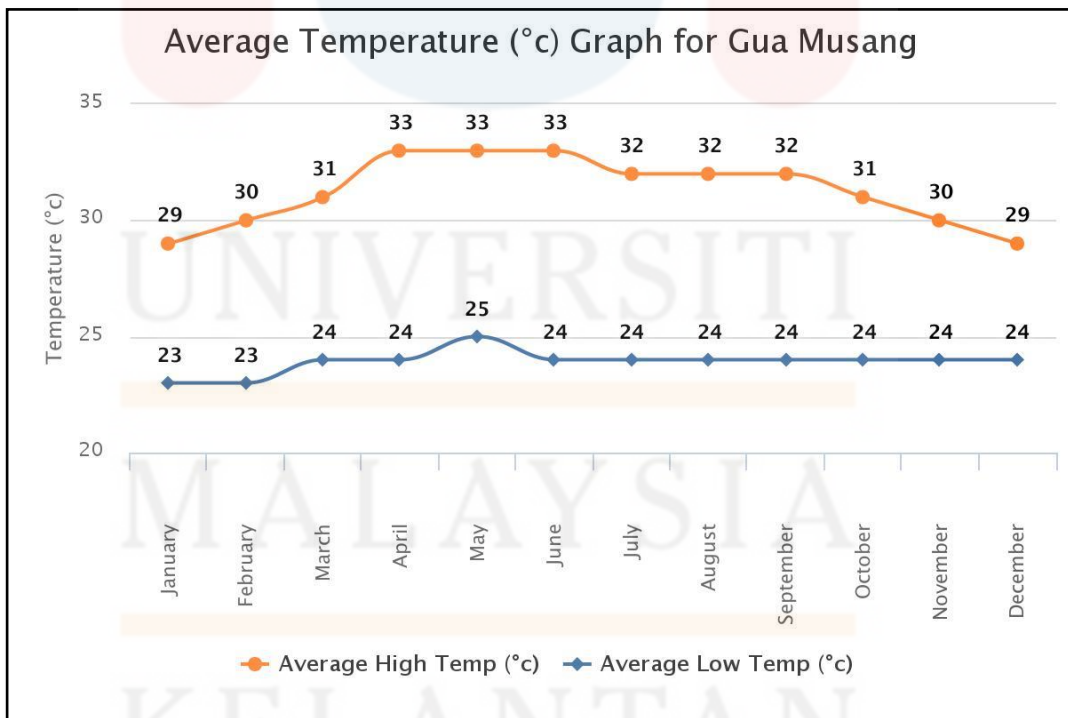
Year	Total rain distribution per month/mm
2011	2505.0
2012	2020.0
2013	1765.5
2014	2721.0
2015	2418.0

(Kelantan Meteorological Department, 2015).

Based on figure 1.3, it shows the average rainfall in millimetre (mm) for Gua Musang district based on data taken from 2000 until 2012. The highest rainfall occurred in November due to the Northeast Monsoon. Figure 1.4 shows average temperature in degree Celsius for Gua Musang district. The lowest temperatures is 23°C that take place in January.



**Figure 1.3 :** The average rainfall (mm) for Gua Musang district based on the data taken from 2000 until 2012. (source : World Weather Online, 2016)



**Figure 1.4 :** The average temperature (°C) for Gua Musang district based on data taken from 2000 until 2012. (source : World Weather Online, 2016)

### 1.5.3 Land used

Land use that has been found in this area are oil palm plantation and rubber plantation (refer figure 1.5 and figure 1.6). The other type of land use is residential area. Oil palm plantation is one of sources of the social economic for the people who lives here.

**Table 1.5.3** : Land use of Kelantan

No.	Category	Area (hectare)	Percentage (%)
1	Forest Reserve	894 271	59.5
2	Agriculture	335 660	22.3
3	Urban	4 967	0.3
4	Mining	3 737	0.3
5	Other : <ul style="list-style-type: none"> <li>• River, dam</li> <li>• Reservoir areas</li> <li>• Cleared areas</li> <li>• Grazing Areas</li> <li>• Mangrove areas</li> <li>• Secondary Areas</li> </ul>	263 565	17.6
6	Total	1 502 200	100

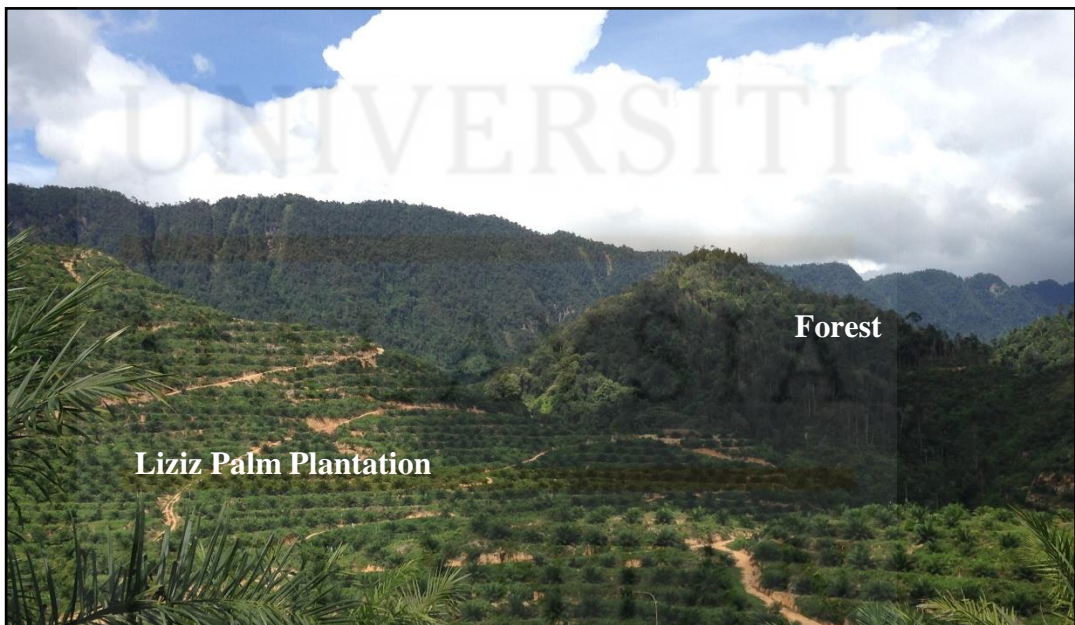
(Department Of Mineral and Geoscience Kelantan, 2000)

Based on table 1.5.3, about 60% of Kelantan are still covered with forest. The southern district of Kelantan which are Jeli, Gua Musang and

Kuala Krai are mainly covered by state land and reserved land. In addition, about 22% of land is being used as agriculture, mostly located within alienated land while urban and mining area land area covering less than 1% of Kelantan state.



**Figure 1.5 :** Land use for palm estate.



**Figure 1.6 :** The forest and oil palm plantation area.

#### 1.5.4 Social Economic

The economic activity for people who live around here is as entrepreneurs, rubber tappers and based on industrial activities. Many grocery stores that can be found along the road Gua Musang-Kuala Betis and along road that connected to study area as shown in figure 1,7 and a few of rubber plantations (shown in figure 1.8) and oil palm plantation also can be observed in study area.

**Table 1.5.4 :** Industrial activities of Gua Musang Resident

Focusing Area	Industrial classification
Gua Musang Town	Food product Craft product Wood product
Chiku Town	Biotechnology and Agriculture product
FELDA and selected PPD	Food product Agriculture product Tourism
Residential area	Food product Agriculture product



**Figure 1.7** : Grocery shop and residential area within study area.



**Figure 1.8** : Rubber estate owned by residents in study area.

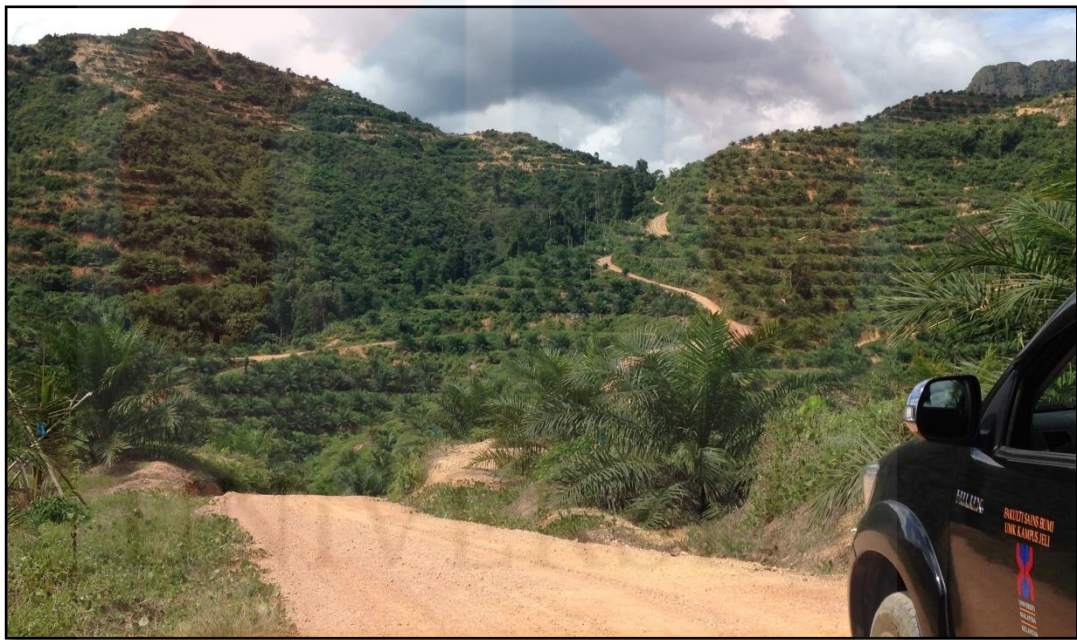
MALAYSIA

---

KELANTAN

### 1.5.5 Road Connection

Figure 1.10 shows pavement road which is Lojing- Cameron Highland highway that can be access by all kinds of vehicles. This road also the only main road that connected to study area. There are also unpaved road as shown in figure 1.9 which is located within rubber plantations and oil palm plantations. Figure 1.11 shows the only bridge that connecting Pos Blau with Gua-Musang Cameron Highland highway.



**Figure 1.9 :** The unpaved road within study area.

MALAYSIA  
KELANTAN



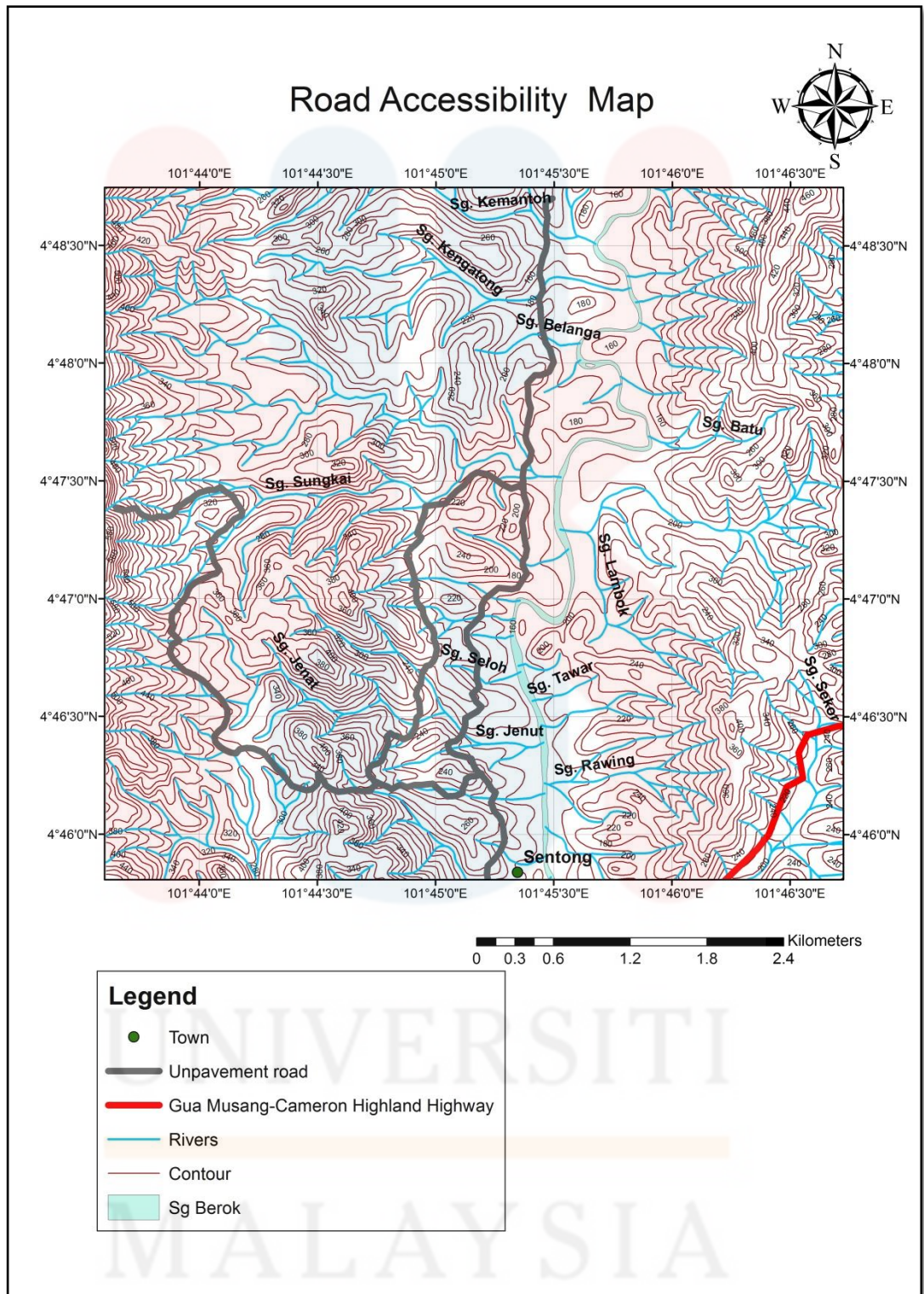


**Figure 1.10 :** The paved road in study area.



**Figure 1.11 :** The bridge at Sg. Berok connecting Pos Blau with Gua Musang-Cameron Highway.

Map 1.3 shows road accessibility within study area, almost 90% of study area is covered with unpaved road.



**Map 1.3** : The road connection within study area.

## **1.6 Scope of study**

This research is conducted at Gunung Ayam area in Lojing, Gua Musang district that located 40 km from main town of Gua Musang. This research is focusing on geological mapping with objective to update geological map with scale 1:25 00. This research also includes structural analysis of study area and relate it with deformation process that take place during ancient time.

## **1.7 Significant of research**

This study will provide conformation about formation and types of rocks within study area. With this study, geological map for study area will be updated. This research will also determine structural analysis of study area. Due to lack of information regarding study area, this research will also provide latest information regarding study area as well as geological map with 1:25 000 scale.

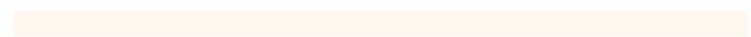
## **1.8 Chapter's summary**

Study geology of the Earth is very crucial for every geologists in order to know and learn true stories about Earth itself. This chapter covers problem statement, research objectives which are to update geological map for study area with scale 1:25 000 and conduct structural analysis and relate it with deformation processes of that area. Besides that, details about study area also briefly explained within this chapter as well. Last, the important of this

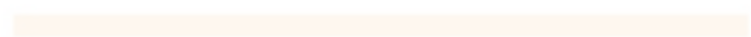
research is that with this research, it will be very valuable for the future researchers to conduct further research at Gunung Ayam area.



UNIVERSITI



MALAYSIA



KELANTAN

## CHAPTER 2

### LITERATURE REVIEW

#### 2.0 Introduction

This chapter will discuss about literature review of past studies that can be relate with this thesis. The purpose of literature review is to give a guidance in writing up the report and summarize past studies that had been done all around the study area.

#### 2.1 Regional Geology of Kelantan

Kelantan is located at the north-eastern part of the Peninsular Malaysia. This state shared boundaries with 3 states in Malaysia which are west Perak, south Pahang and east Terengganu. Kelantan state also shared boundary with one nation, Thailand. There are ten districts in Kelantan, they are Tumpat, Pasir Mas, Pasir Puteh, Kota Bharu, Bachok, Tanah Merah, Machang, Jeli, Kuala Krai and Gua Musang.

Based on the Department of Minerals and Geosciences (2003), there are six major type of rocks can be found in this state which are sedimentary rock, unconsolidated sedimentary, metamorphic rock, metasedimentary rock, volcanic rock and granitic rock.

The northern part of Kelantan containing unconsolidated sedimentary, representing the flat Kelantan alluvial plain of Quaternary age. In the other

hand, on the eastern part of Kelantan, the occurrence of volcanic rocks formed north-south elongated body found at the central zone and bordering with the Boundary Range Granite . These volcanic rocks are made up of acidic to intermediate volcanic.

At the southern part of Kelantan state, rocks with aged from lower Palaeozoic in Bentong group lies toward western part. While, at central part of Kelantan, lithology of rocks consist of sediment aged Permian to Triassic. In the eastern part, the rocks aged from Jurassic to Cretaceous can be found.

### **2.3 Formation in Gua Musang**

Gua Musang district consists of two formation, which are Gua Musang formation and Gunung Rabong formation. Types of rocks that can be found at Gua Musang area were rocks with argillite unit that had been undergoes low graded metamorphism turned into phyllite and slate. Carbonate rock such as limestone turned into marble due to contact metamorphism process. At some part of Gua Musang, the appearance of sandstone and conglomerate can be observed especially at Gunung Rabong area. Majority of those argillite unit consist of sandstone interbedded with tuff that originated from volcanic activities. The dominant unit in Gua Musang is argillite unit followed by limestone unit. However, the occurrence of carbonate rock which is limestone formed karst landform. These rocks units called as Gua Musang formation. Gua Musang can be divided into four divisions, they are Kuala Betis, Gua Musang, Aring and Gunung Gagau.

Gua Musang formation was introduced by Yin (1965). Based on the Department of Minerals and Geosciences Malaysia (2003), sedimentary rocks aged Permian exposed on the eastern part of Kelantan where they were overlaid by Lower Paleozoic sequences in southwest Kelantan and grouped as Gua Musang formation. These formation is made up of argillaceous with calcareous bedding, pyroclastic rocks and Taku schist. The age of the Gua Musang formation is determined by the occurrence of many fossils at many area around Gua Musang formation. Bivalvia fossils from genus *Claraia* age Early Triassic had been found in Gua Musang (Ichikawa, K. & Yin, E. H., 1996). At one of the part of Gua Musang district, in Pos Belau, some radiolarian fossils can be found in chert layers which are *Pseudoalbaillella lomentaria* Ishiga and Imoto, *Pseudoalbaillella sakmerensis* Konzur, *Spongosphaeradiscus shaiwaensis* Wang and many more. Based on these fossils, it's conclude that the age for chert layer at that area is Permian (Dzulkafli, M. A et.al, 2010).

#### 2.4 Stratigraphy

The age of Gua Musang formation is from Permian to Upper Triassic where it is estimated to be 65 m thick with crystalline limestone, shale, chert that interbedded with mudstone as well as conglomerate.

According to Aw (1974), Kuala Betis area is located at the western part of Gua Musang with similarities in term of lithology that had been identified in Gua Musang formation. The Gunung Ayam conglomerate contains conglomerate sandstone sequence. Aw (1974) also stated that, the western part

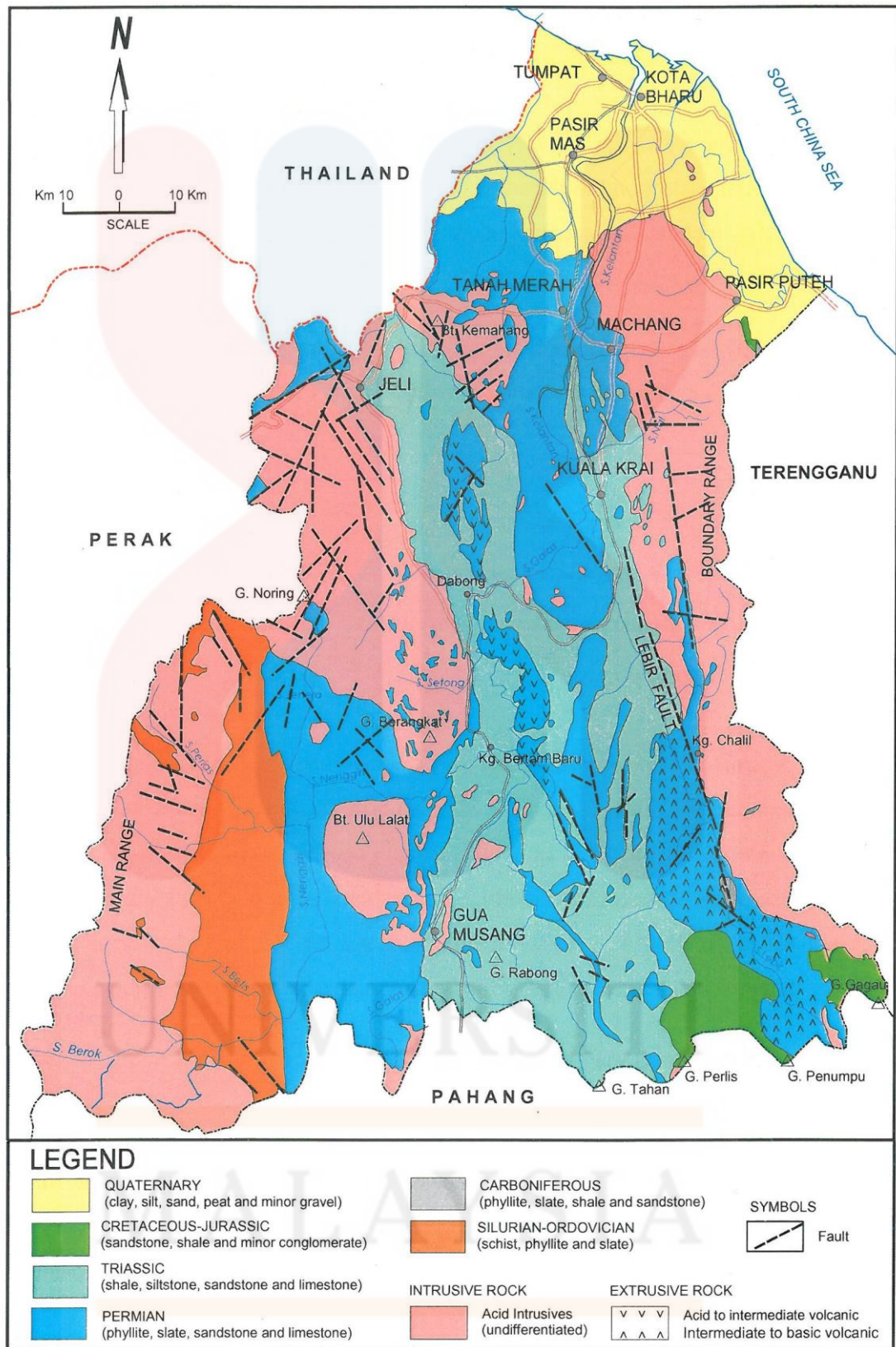
of Gua Musang which is Kuala Betis and Nenggiri area had the rocks aged Permian to Triassic which are including argillite, limestone and conglomerate.

There are about seven tectonic packages within suture zone rocks can be found which are phyllite, schist, melange, sandstone, mudstone, chert as well as serpentinite that had stacked imbricate structure in Ulu Kelantan (Tjia, H. D & Almashoor, S. S, 1993)

Next, figure 2.1 shows geological map of Kelantan that showing distribution of the rocks in Kelantan state. At the North part of Kelantan, the map shows that area is dominated by Quaternary sediment such as silt, clay, sand, peat and some minor gravel. For the middle area of the state, its dominated by Triassic sedimentary rock such shale, siltstone, sandstone and limestone followed by Permian sedimentary rocks and metamorphic rock such as sandstone, limestone, phyllite and slate. From this figure, study area located in this Permian region. There also some acid to intermediate volcanic and intermediate to basic volcanic rocks which is located at Gua Musang and Kuala Krai district.

UNIVERSITI  
MALAYSIA  
KELANTAN





**Figure 2.1 :** This geological map shows distribution of rocks in Kelantan state. From the map, it is shown that study area is composed of metamorphic rock and sedimentary rocks from Permian age . (Department of Minerals and Geoscience Malaysia, 2003 )

## 2.5 Structural Geology

According to Tjia and Syed Sheikh Almashoor (1996), rocks that located within the suture along the East-West Highway can be divided into seven tectonic unit. All those tectonic setting had formed an imbricate structure with high angle faults contact with each other. The structural studies of deformation within Bentong-Raub Suture Zone shows that the suture zone had undergone progressive-transpressive deformation (Ibrahim Abdullah and Jatmika 2003).

Based on the Shuib. M. K. (1994c), along East-West highway and Gua Musang-Cameron Highland road, there are thinly bedded chert overlies massive shale and this chert was deformed by bedding. The bedded chert shows an isoclinal fold that had been refolded by steep North-South reverse dextral fault.

Tjia (1986, 1987, 1989a, 1989b), Tjia and Zaiton (1985) conclude that the tectonic transport was primarily toward west during Late Palaeozoic forming eastward subduction. Basir Jasin, Jatmika Setiawan & Ibrahim Abdullah (2010) states that structurally Kelantan state is divided in the West part by Olistrostrom while at the East part by Lebir Fault Zone. At the middle part of Gua Musang formation there is a great fold toward North-South up to North-Northwest – South-Southeast.

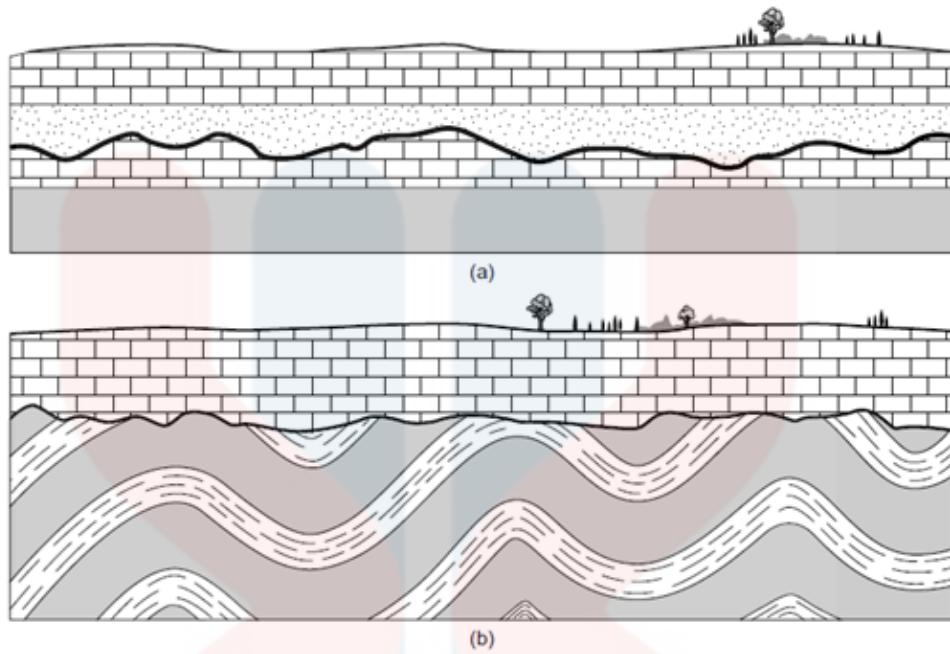
In the other hand, there are two great faults can be found in Gua Musang formation. The first fault is right lateral fault with strike between  $N30^{\circ}$ - $45^{\circ}$ E with dip angle in between  $60^{\circ}$  -  $70^{\circ}$  to SE and the second fault is left lateral fault with strike between  $N330^{\circ}$  -  $340^{\circ}$ E with dipping at  $60^{\circ}$  -  $70^{\circ}$

toward ENE-WSW. The direction of major compression which formed folding and faulting within Gua Musang formation is between WNW – ESE up to ENE – WSW.

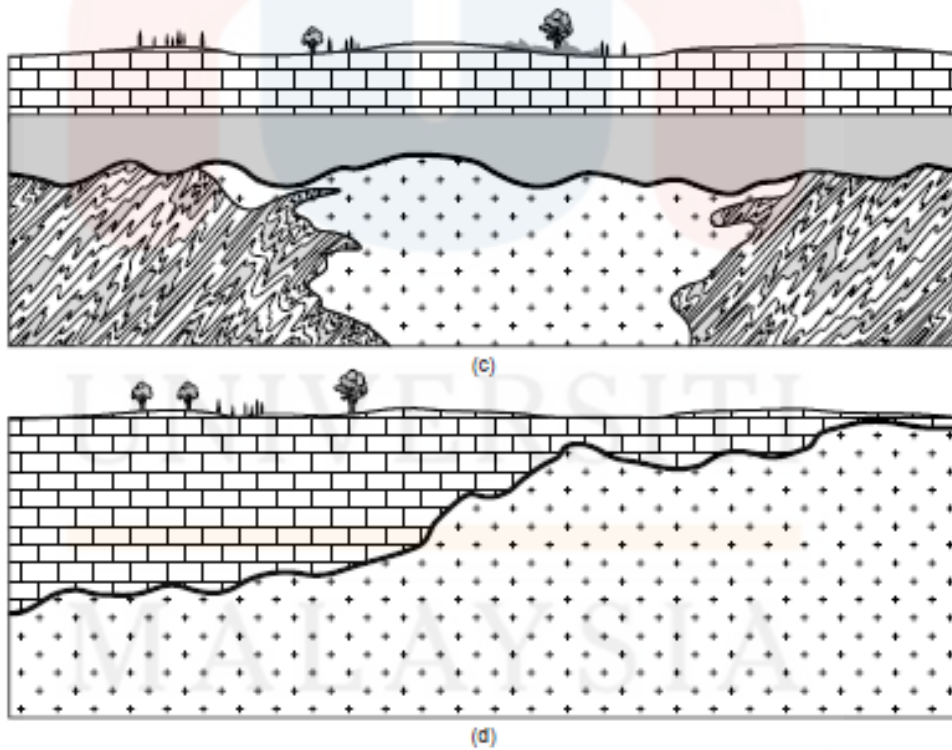
Fundamental structures can be divided into three, they are contact, primary structure and secondary structure. Primary structure is the structures that produced during the formation of the rock itself. The example of primary structure are depositional contact, unconformable contact, cross bedding and vesicles in basalt. Secondary structures is any structures that produced after the rock body is formed. Example of secondary structures area folds, faults, joints, shear fractures, tectonic fabric such as cleavage, foliation and lineation. Contact is the boundaries that separate a rock body from another. There are three basic types of contact which are :

1. Depositional contact : occurs when sediment layer is deposited over pre-existing rock.
2. Fault contact : occurs when two block of rock are place side by side by a fracture where sliding occurred.
3. Intrusive contact : occurs when one rock body cuts across another rock body. Usually can be observed where igneous rock intrude country rock.

Figure 2.2 and Figure 2.3 show the principle types of unconformities.



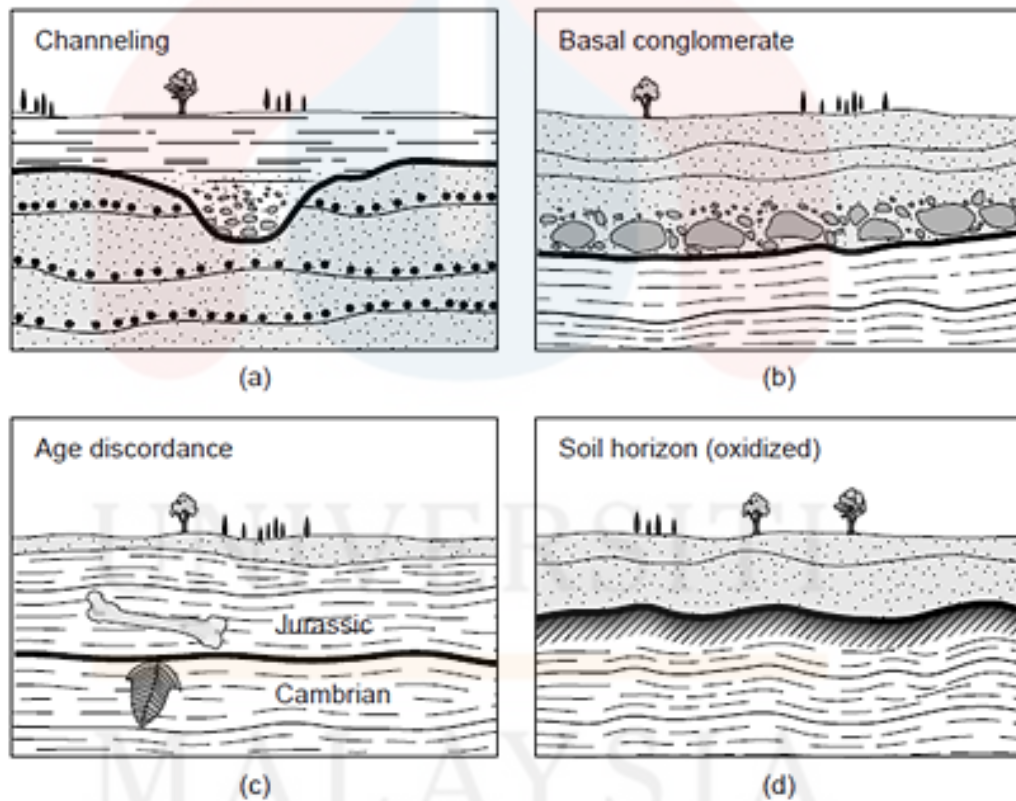
**Figure 2.2 :** (a) Disconformity, (b) Angular unconformity. (source : Van Der Pluijm, Ben A., 2004)



**Figure 2.3 :** (c) Nonconformity, (d) Buttress unconformity. (source : Van Der Pluijm, Ben A., 2004)

Some of the features to identify unconformities by observed any occurrence of scour channels in sediments, basal conglomerate, age discordance from fossil evidence and soil horizon. From details, it shows in Figure 2.4.

If strata in the sequence contain fossils, by determine the fossils' species and their age, the gap in the fossil succession can be recognize. Unconformity also can be marked by a surface of erosion such scour features and paleosol.



**Figure 2.4** : Features used to identify unconformities : (a) scour channels in sediments, (b) basal conglomerate, (c) age discordance from fossil evidence and (d) paleosol. (source : Van Der Pluijm, Ben A., 2004)

Next, when countering a sedimentary rock outcrop, the most obvious characteristic is stratification also known as bedding. Recognition of bedding is critical in structural analysis as the bedding provides a reference for describing deformation of sedimentary rock.

As the Law of Original Horizontality, sediments are initially deposited in form horizontal or nearly horizontal layers. If an outcrop showing tilting or folding, it can be conclude that, this outcrop undergone deformation.

The study about depositional structures within beds and on bedding surface is very important in tectonic analysis because its contain information regarding the depositional environment, stratigraphic facing, current direction. Facing indicators will determine whether a bed is right-side-up or overturned. Table 2.1 shows the stratification terminology.

**Table 2.1 :** Some commonly used terms that are related to stratification.

Term	Description
Bedding	Primary layering in sedimentary rock that formed during deposition, display changes in texture, colour and composition.
Compaction	Unlithified sediments that have been squeezed due to pressure that applied by the weight of overlying beddings.
Overturned beds	Beds that have been rotated past vertical in the Earth-surface frame of reference.
Parting	The tendency of sedimentary layers to fracture or split along parallel to bedding. This incident due to weak

	bonds between beds with different composition.
Strata	A sequence composed of layers sedimentary rock.
Stratigraphic facing	The direction to the depositional top of beds (the direction to younger strata also known as younging strata).

Besides that, geologist also have developed special words for describing specific types of bedding as shown in Table 2.2.

**Table 2.2** : Terms used to describe types of bedding.

Term	Description
Massive beds	The beds that are very thick with several metres and show no internal layering. Massive beddings formed in sedimentary environments where large quantities of sediment are deposited rapidly or in bioturbation environment.
Thick Beds	Beds that are range between 30 to 100 cm thick.
Medium beds	Beds that are 10-30 cm thick.
Thin beds	Beds that are less than 3 cm thick.
Thinly laminated beds	Beds that are less than 0.3 cm thick.
Rhythmic beds	A sequence of beds in which the contrast between adjacent beds is repeated periodically for a substantial thickness of strata.

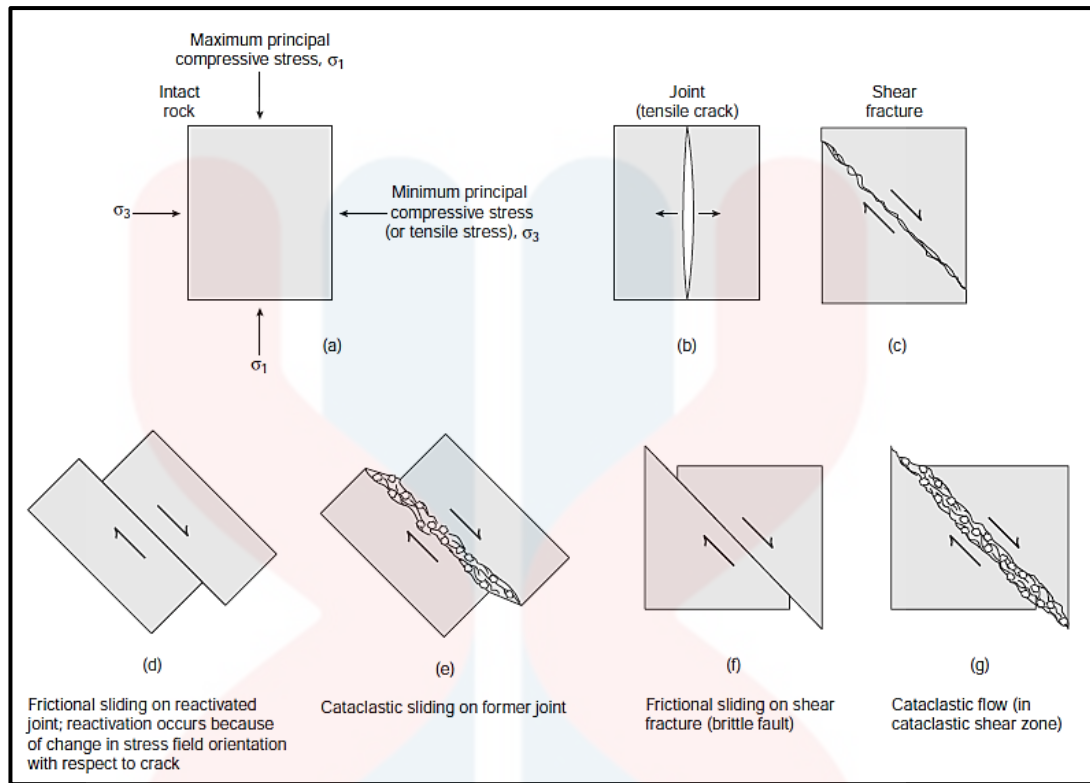
### 2.5.1 Brittle Deformation

Brittle deformation occurs in a solid material due to the growth of fractures or/and sliding on fractures when they formed. The change is permanent. Brittle deformation can cause other structures such as fault, fractures, joint, vein, and dike.

Fracture can be define as any surface of discontinuity. Veins is a fracture that fills with minerals precipitated out of hydrous solution while if it fills with igneous or sedimentary rock which originating from other place , it is called dike. Joint is a natural fracture in rock with no shear displacement. Joint also can be called as cracks or tensile fractures.

Based on Figure 2.5, (a) showing the orientation of the remote principal stress directions to an intact rock. (b) tensile crack formed parallel to  $\sigma_1$  and perpendicular with  $\sigma_3$ . (c) shows the shear fracture that formed at an angle of  $30^\circ$  to the  $\sigma_1$  direction. (d) shows a tensile crack that has been reoriented becomes fault which undergone frictional sliding. (e) the tensile crack that has been reactivated as a cataclastic shear zone. (f) its shows the shear fracture that has evolved into a fault. (g) the tensile crack that has evolved into a cataclastic shear zone.





**Figure 2.5** : Types of brittle deformation. (source : Van Der Pluijm, Ben A., 2004)

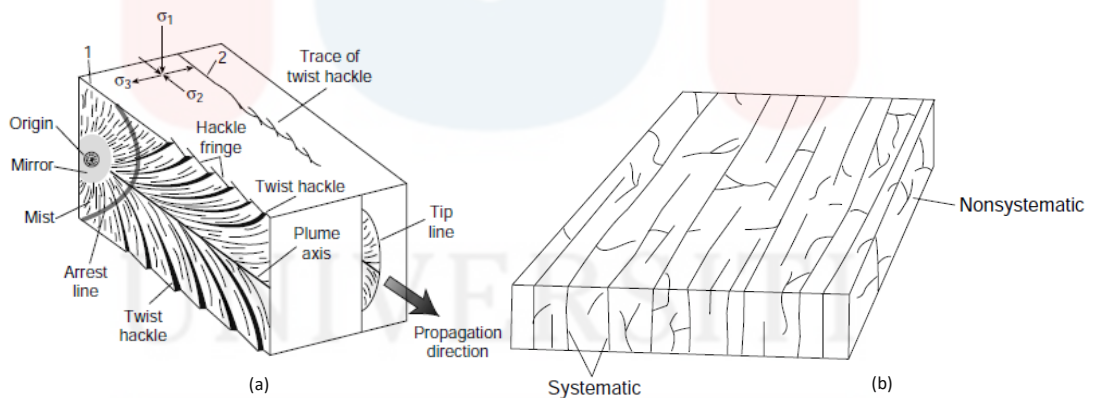
### 2.5.2 Joints and Veins

Joint is natural, unfilled, planar or curvilinear fractures non-geometric, tensile fractures that form parallel to the principal plane of stress that contains the  $\sigma_1$  and  $\sigma_2$  direction and perpendicular to the  $\sigma_3$  trajectory. Table 2.3 shows the terminology for joints. Figure 2.6 shows the block drawing of various components of ideal plumose joints, systematic joints and non-systematic joints in a body of rock while Figure 2.7 shows the occurrence of joints at the faulting region.

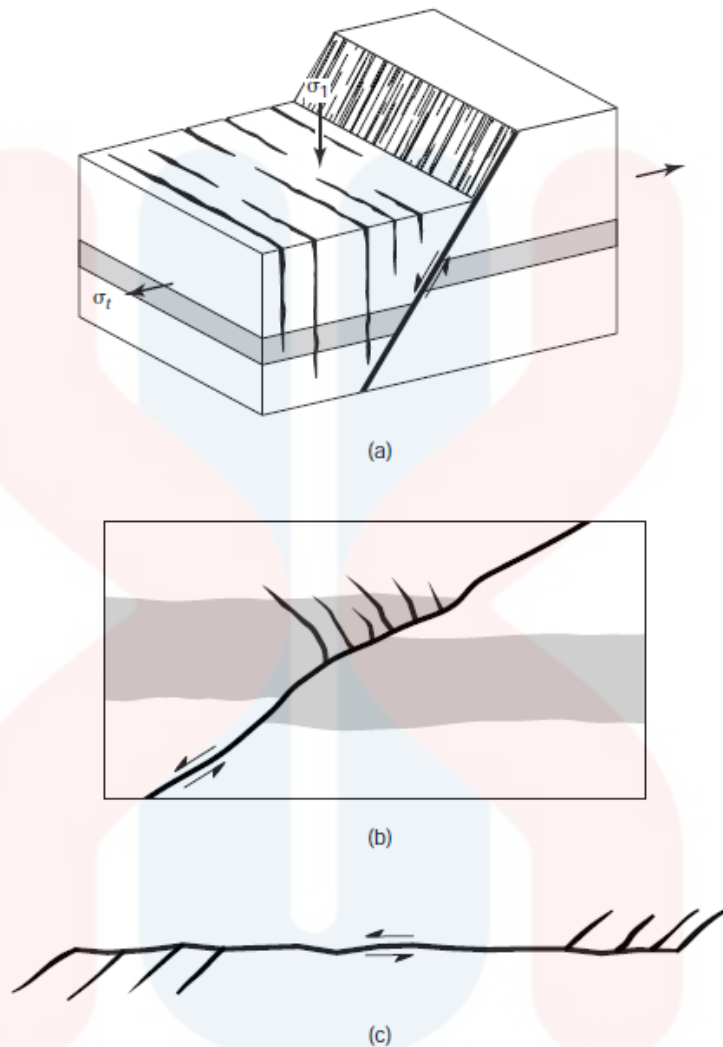
**Table 2.3 : Joint Terminology.**

<b>Terms</b>	<b>Description</b>
Conjugate system	Two set of joints oriented with dihedral angle between the set is approximately 60°.
Cross-strike Joint	Joints that cut across the general trend of fold hinges in a folded rock area.
Cross Joints	Joints that discontinuous which cut across the rock between two systematic joints with high angle orientation.
Dessication Crack	Also known as mud crack is joints that formed in a layer of mud when it dries and shrinks. It break the layer into roughly hexagonal plane.
Joint Array	Any group of joints either systematic or non-systematic.
Joint Set	A group of systematic joints
Systematic Joints	Planar joints that occur as part of a set in which the joints is parallel or sub-parallel to one another and which are relatively evenly spaced from each other.

<p>Non-systematic Joints</p>	<p>A joints that is not planar and not parallel with the nearby joints.</p>
<p>Sheeting Joints</p>	<p>Also known as exfoliation. It formed near the ground surface and roughly parallel with the ground surface. Its resemble delaminating onions.</p>
<p>Plumose Joint</p>	<p>Resemble the imprint of a feather, a subtle roughness on the surface of some joints usually in fine grained rock.</p>



**Figure 2.6 :** (a) Block diagram showing the various components of an ideal plumose structure on a joint. The face of joints 1 is exposed while joint 2 is within the rock (b) Block diagram showing the occurrence of both systematic and non-systematic joints in a body of rock. (source : Van Der Pluijm, Ben A., 2004)



**Figure 2.7** : (a) Formation of joints in the hanging-wall block of a region of normal faulting. (b) Formation of joints above an irregularity in a reverse fault surface. (c) The occurrence of pinnate joints along a fault. (source : Van Der Pluijm, Ben A., 2004)

Vein is the fracture that filled with mineral crystals that precipitated from a watery solution. The most common vein fill are quartz and calcite, but other minerals such ore minerals, zeolites and chlorite also can filled the veins. The origin of vein come from joints, faults or crack that located in faults region. Vein come in various sizes, some are narrower and shorter that a strand of hair while others can comprise massive tabular accumulations that have meters across with tens of meters long. Vein arrays are the term used

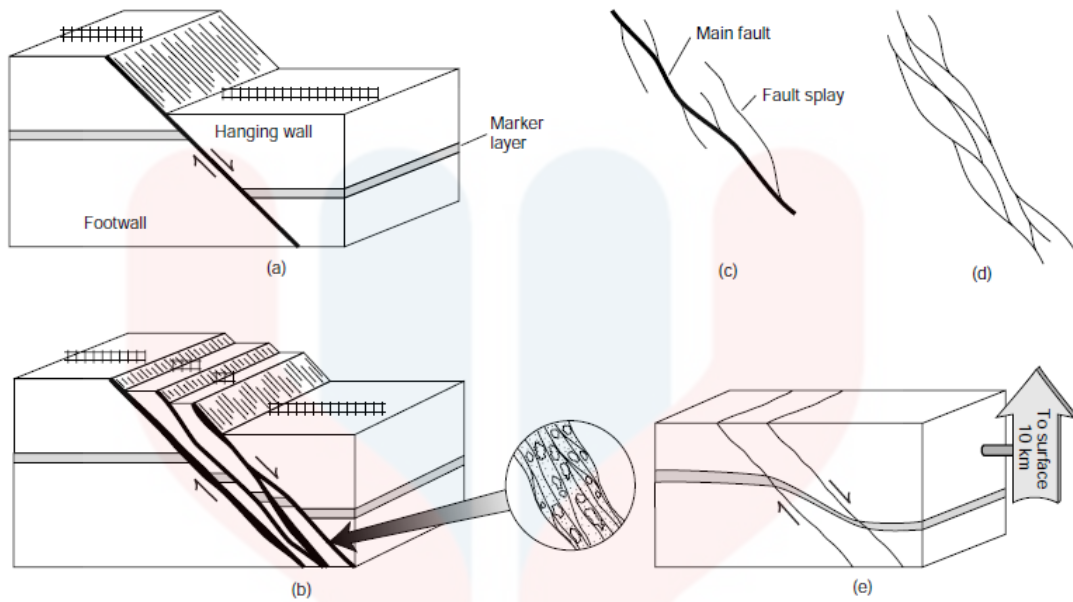
for groups of veins. It have two forms which are planar array of veins and stockwork array of veins. Planar arrays usually formed in a systematic joints set regions while stockwork array formed in region where the rock has been shattered due to deformation processes such as folding and faulting or due to high fluid pressure that acting upon the rock. Figure 2.8 shows the types of vein arrays.



**Figure 2.8** : The types of vein arrays. Vein fill is dark (a) Planar array of veins. (b) Stockwork array of veins. (source : Van Der Pluijm, Ben A., 2004)

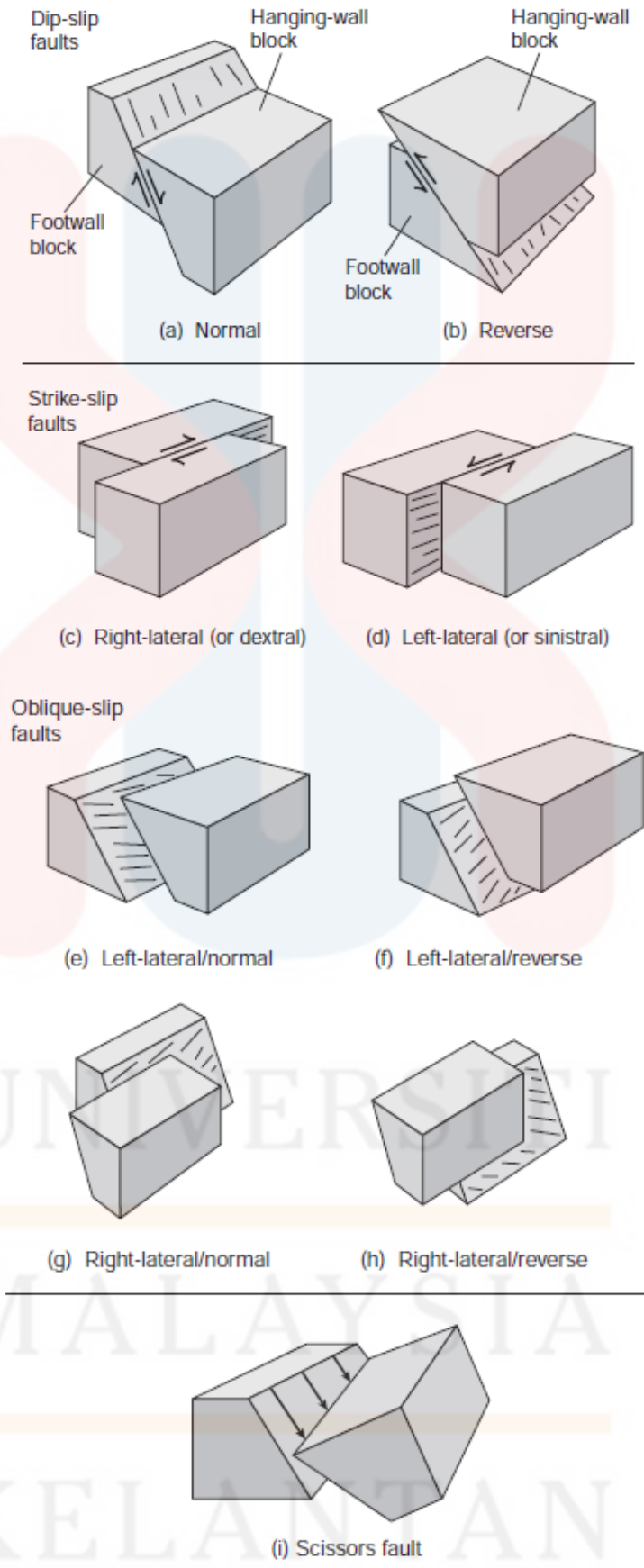
### 2.5.3 Faults

Fault is define as any surface in the Earth across which measurable shear displacement. Faults are fractures that slip develops primarily by brittle deformation processes. Fault zone is the brittle structures that loss cohesion and slip occurs on several faults within a band definable width as shown in Figure 2.9 b. figure 2.9 shows the differences between faults, fault zones and shear zone.



**Figure 2.9** : Sketches illustrating differences between faults, faults zones and shear zone. (a) Fault. (b) Fault zone, with cataclastic deformation adjacent to the fault surface. (c) Sketch illustrating the relation between fault and fault splay. (d) shows the anastomosing faults in a fault zone. (e) a shear zone , the displacements are shown to intersect the ground surface whereas the shear zone occurs at depth in the crust. (source : Van Der Pluijm, Ben A., 2004)

Figure 2.10 shows the type of faults. There are a few types of faults which are dip-slip faults, strike-slip faults, oblique-slip faults. The dip-slip fault has the slip direction that parallel to the dip of the faults with rake between  $80^{\circ}$  -  $90^{\circ}$ . Strike-slip faults are generally steeply dipping to vertical. The slip direction is parallel to the fault strike. On the other hand, the oblique-slip faults is faults with a slip direction between  $10^{\circ}$  and  $80^{\circ}$ . The slip direction of oblique-slip fault has a rake that not parallel to the strike or dip of the fault. the classification of brittle fault rock is presented in Table 2.4.



**Figure 2.10** : The block diagram sketches showing the different types of fault. (source : Van Der Pluijm, Ben A., 2004)

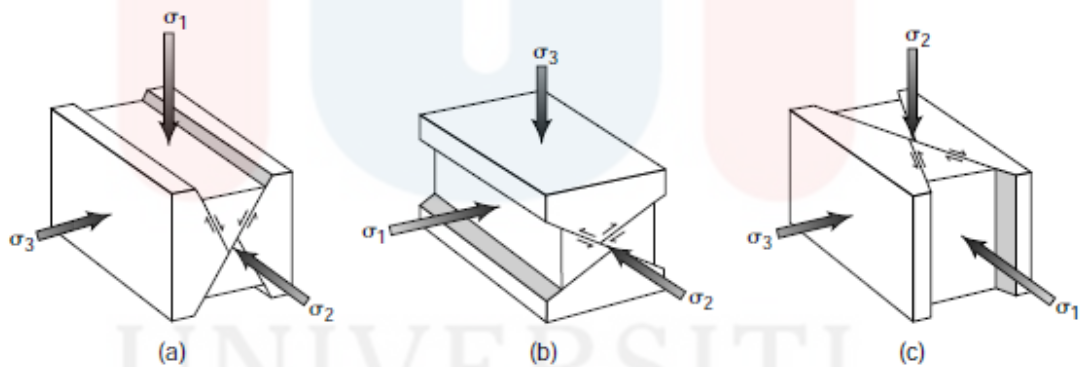
**Table 2.4 :** The classification of brittle fault rock.

Term	Description
<b>Cohesive Brittle Fault Rock</b>	
Cataclasite	Fault rock composed of broken, crushed, rolled grains. It is a solid rock that does not disintegrate when struck with a hammer.
Argille scagliose	Fault rock that forms in very fine-grained clay or mica-rich rock such shale or slate. It is characterized by the presence of a very strong wavy anastomosing foliation. The rock also breaks into little platy flakes.
Pseudotachylyte	A microcrystalline material that forms due to frictional heating melts rock during slip on a fault. the thickness is generally from mm to cm.
<b>Noncohesive Brittle Fault Rock</b>	
Fault gouge	Rock composed of material that undergone pulverization due to tectonic activities. The grains in fault gouge are less than 1 mm in diameter normally unconsolidated rock type.



Indurated gouge	The fault gouge that has been cemented together by mineral precipitated due to groundwater circulation. Also known as vein-filled breccia.
Fault breccia	The rock that composed of angular fragments.

Faulting only occurs when the differential stress ( $\sigma_d = \sigma_1 - \sigma_3 = 2\sigma_s$ ) does not equal zero. Figure 2.11 shows the Anderson's theory of faulting predicts.

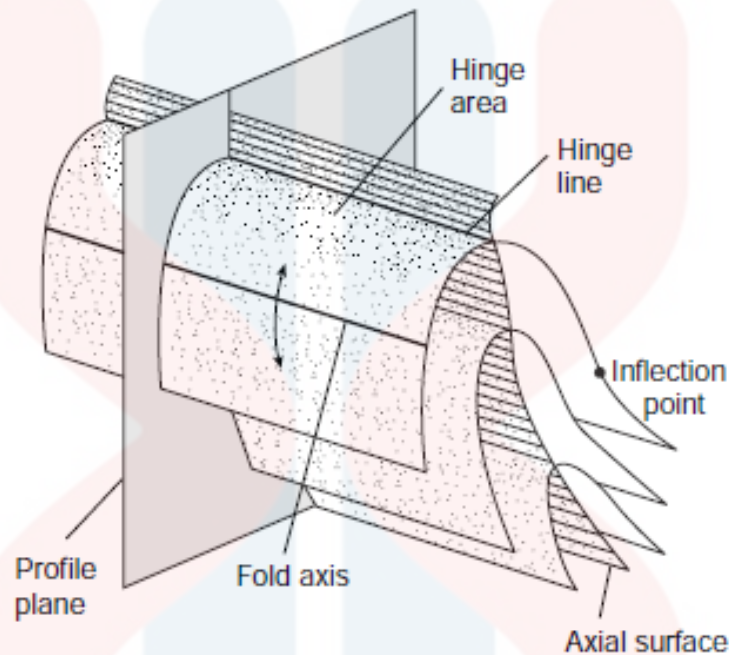


**Figure 2.11** : Anderson's theory of faulting predicts. (a) normal fault. (b) reverse fault or trusts faults . (c) strike-slip faults. (source : Van Der Pluijm, Ben A., 2004)

### 2.5.4 Ductile Deformation (Folds)

Ductile deformation cause the rocks to bend or fold. Fold is a structural feature that formed when planar surface are bent or curved. The deformation is heterogeneously and distributed over the entire structure. Instead

of fracturing or cracking, the kinking, dissolution, grain sliding and crystal plasticity dominate. Figure 2.12 shows the basic geometric elements of a fold.

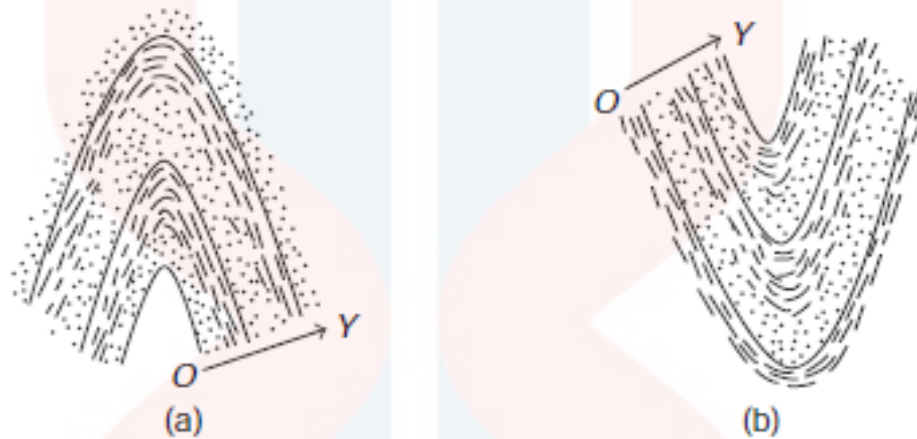


**Figure 2.12** : The terminology of a fold. (source : Van Der Pluijm, Ben A., 2004)

Hinge line is the line of greatest curvature in a folded surface. Hinge area is the region of greatest curvature and separates the two limbs. Limb is the less curved portion of a fold. The profile plane is the surface that perpendicular to the hinge line. The fold generator in cylindrical folds known as fold axis. Inflection point is define as the position in a limb where the sense of curvature changes. The axial surface is the surface that containing the hinge lines from consecutive folded surfaces.

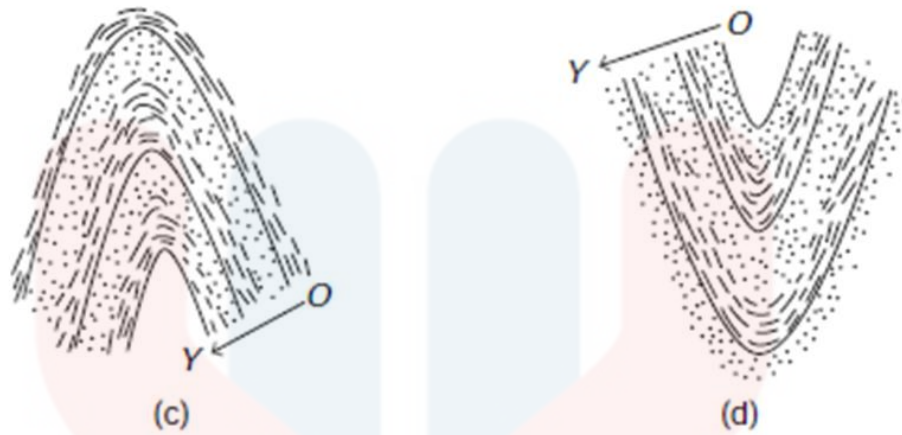
Next, wavelength is the distance between two hinges of the same orientation. If some layers have different wavelength or amplitudes the folds are disharmonic. If the successive layers in a folded stack have same

wavelength and amplitude, the fold is called harmonic. Figure 2.13 shows the fold shape and fold facing.

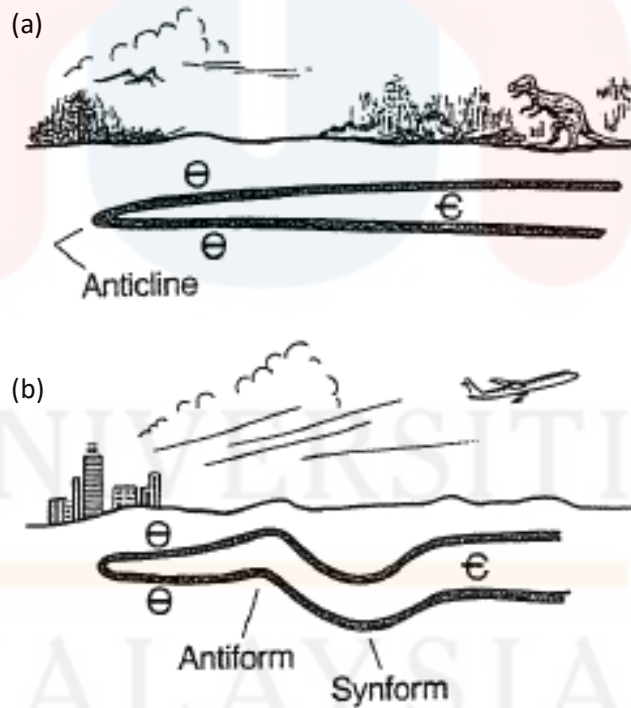


**Figure 2.13 :** (a) The anticline, an upward facing synform. (b) The fold is syncline, the downward facing antiform. Younging direction is indicated by  $O \rightarrow Y$  arrow.(source : Van Der Pluijm, Ben A., 2004)

It is quite rare for anticlines and synclines to be completely upside down. A fold is considered to be overturned if at least one of its limbs is overturned. Figure 2.14 shows the schematic illustration regarding the overturned folds. There also recumbent fold, recumbent define as the fold lies on its side. Isoclinal is the term used when the limbs of the fold are equally inclined. Figure 2.15 (a) shows the example of recumbent, isoclinal anticline. On the other hand, Figure 2.15 (b) shows the early-formed isoclinal fold after it has been modified by a second folding. The anticline is no longer perfectly recumbent. It is deflected into convex-downward and convex-upward superposed folds.



**Figure 2.14** : The anticlined and synclined overtuned folds. Younging direction is indirected by  $O \rightarrow Y$  arrow. (source : Van Der Pluijm, Ben A., 2004).



**Figure 2.15** : An example of regional-scale superposed folding. (a) Recumbent, isoclinal anticline, of pre-Jurassic age. (b) Antiformal and synformal folding of the recumbent, isoclinal anticline. (source : (Davis G. H, 1996)

## CHAPTER 3

### MATERIALS AND METHODS

#### 3.1 Introduction

This research can be divided into five phases, which are preliminary research, field study, laboratory work, data analysis and report writing. In order to obtain and analyse data, materials and methods were examined and choose to fulfil data collection regarding study. Preliminary research contain two components, which are literature review and creating base map based on desk study and remote sensing with help of ArcGIS 10.3 Software. Literatures reviews was done from the sources of the data regarding the study area which can be found in libraries, journals, government books and research notes, books and e-publications. Next, fieldwork is conducted by using mapping activities.

#### 3.2 Preliminary researches

Many researches had been conducted around Gua Musang district, but the previous researches gave more attention toward sedimentology, stratigraphy, palaeontology, hydrogeology and geology heritage rather than structural and geomorphology. The example of researchers and their research are “Geological

Studies to Support the Tourism Site : A Case Study in the *Rafflesia* Trail, near Kampung Jedip, Lojing Highland, Kelantan, Malaysia” by Nazaruddin, D. A. et. Al in 2014, “Geoheritage Conservation of Paleontological Sites in Aring Area, Gua Musang District, Kelantan, Malaysia” by Dony Adriansyah Nazaruddin and Ahmad Rosli Othman in 2014 and “Permian Ammonoids from Kuala Betis area, Kelantan and their paleogeographic significance” by Mohd Shafeea Leman in 1994.

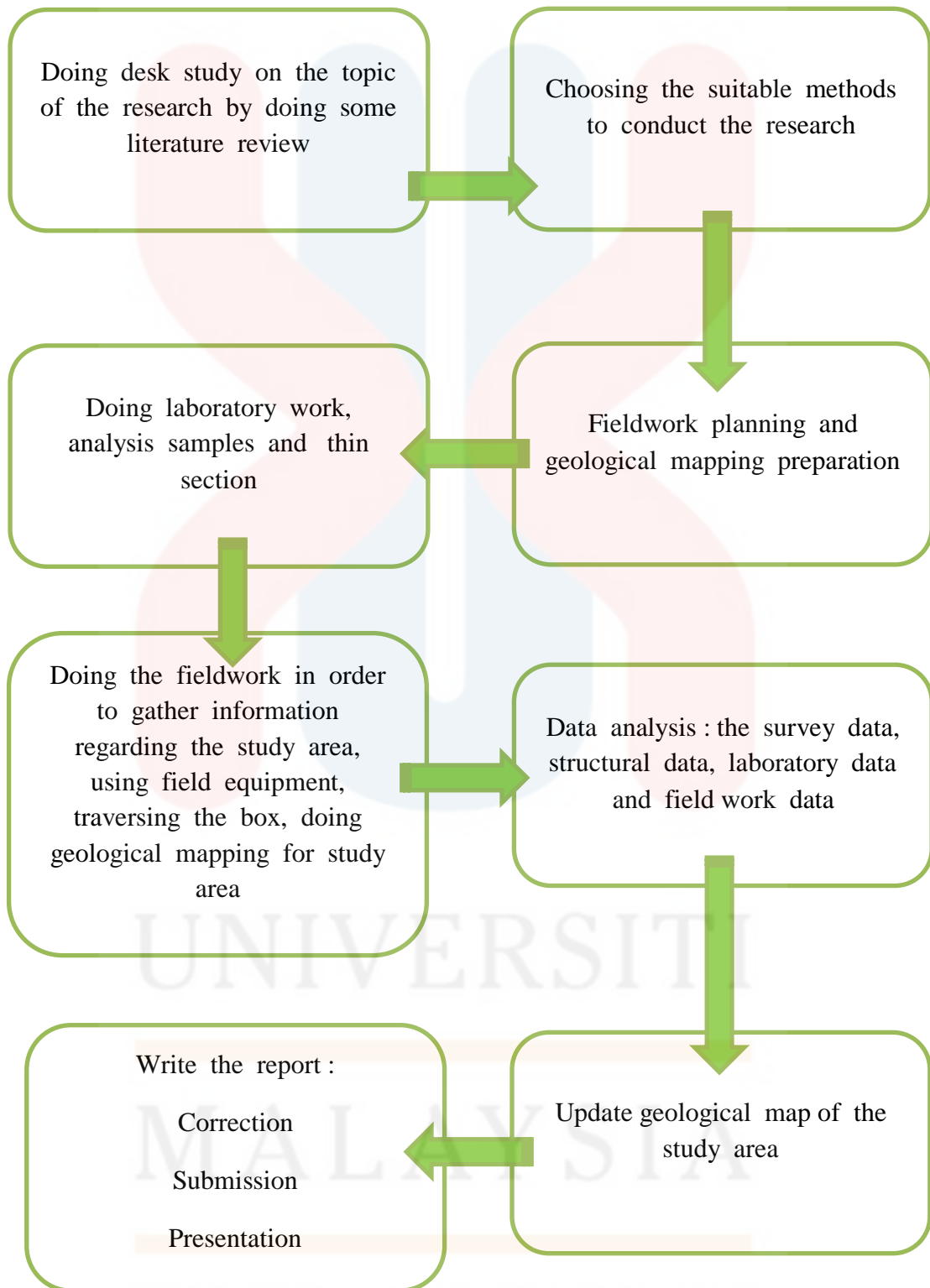
In order to know about geological condition of the study area, preliminary researches need to be studied as there were several researches had been conducted in Gua Musang. The study area were located at Jalan Lojing – Cameron Highland and near with Pos Belau. However, without geomorphological specification from the previous research, geology map cannot be produces as structural geology that was major part of this research and need to be accomplished with a mapping method. Both structural map and geological map are being produced using ArcGIS software. The data from fieldwork activities regarding structures were then analysed by using Stereonet software as well as GeoRose software . Besides that, by using ArcGIS software as well, a few other maps can be produced such as traverse map, geomorphology map, water bodies map and geological hazard map.

Next, aerial photographs and terrain map of the study area were taken from the Google Earth and Google terrain map which is very useful to determine lineaments in study area. Those photographs also can be used to digitize base map as well as determining potential area where geological structures such as faults might occurs. Furthermore, those aerial photo also

provide updated contours pattern, road connections, drainage patterns, land use, rivers and landforms roughly within study area.

The location of study area is close to main road connecting Gua Musang to Cameron Highland and residential areas of ‘Orang Asli’ which is Pos Belau. There are many small rivers formed inside palm oil farm plantations. Most of small rivers within study area were formed because of big flood during 2014. There are some types of drainage patterns such as dendrites and parallel can be observed from base map of study area. The highest peak in study area which is part of Gunung Ayam is 600 m from the datum.

**Research Flow Chart**



**Figure 3.1 :** The research flow chart from beginning of research until presentation.



### 3.3 Materials

The materials that's very useful to conduct this study are fieldwork materials and laboratory materials.

The fieldwork materials consist of notebook for data collecting and base map which gave information about study area while for laboratory materials, the machines or tools had been used are laboratory instruments such as thin section machine, petrographic microscope and others.

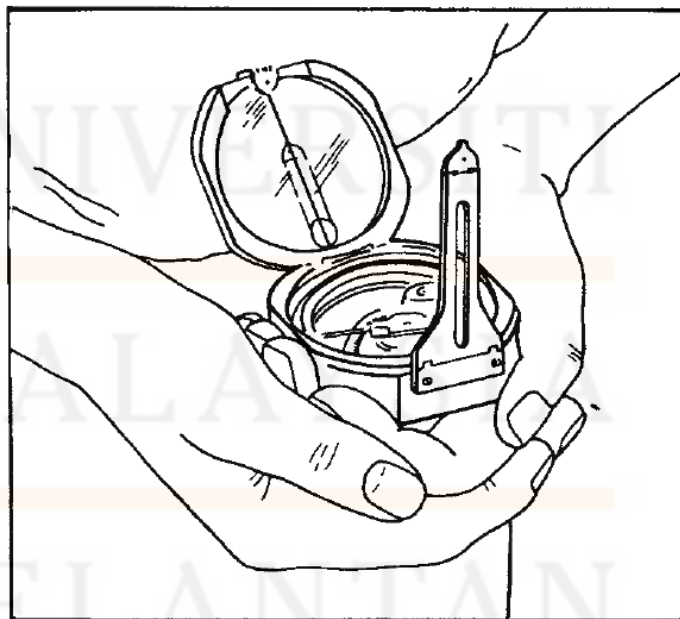
In order to conduct geological mapping to gather rocks samples and field information, it is important to have topographic map, geological hammer, Global Positioning System instruments (GPS), sample bags, hydrochloric acid solution, compass, hand lenses and other field equipment (figures shown in Table 3.2).

Geological hammer is used to break the rocks into smaller pieces for sampling purposes. The common pattern used has one-square-faced end with chisel end. There also a "prospecting pick" which has a long pick-like end that can be used for digging in soil and can be inserted into crack for levering out loose rock. Besides that, hammering alone is not always the best way to collect rock specimen. A cold chisel is needed to break out a specific piece of rock sample.

Next, GPS is a modern device using alkaline batteries as source of energy which can pinpoint any position on Earth's surface with help of satellites that orbiting the Earth. As GPS needs line-of-sight to multiples

satellites at the same time, it does not work in thick forests or steep valleys. GPS also can be used for tracking distance within study area.

Compass is one of the oldest instruments that had been used by modern and ancient geologists for navigation and orientation that shows direction relative to the geographic cardinal directions which are North, South, East and West. The common brands for compass are Brunton and Finnish Suunto which had built-in clinometers. Suunto compasses have transparent bases so that bearings can be plotted directly onto a map by using it as a protractor. With all these compasses, the orientations of geological planes such as strike and dip angle of the bedding for rocks can be determined. The Brunton company suggested that the compass is held at waist height as illustrated in Figure 3.2. In order to take a measurement, the needle does not have to stop swinging, just wait until the swing is only a few degrees and read the average of the swing.



**Figure 3.2 :** The suggested way to use a Brunton compass when taking the bearing on a distant point. (reproduced by courtesy of the Brunton company, Riverton, Wyoming)

Compass can be calibrated in several ways either the traditional 360 (degrees) or the continental 400 (grads) to a full circle. For comparisons, have a look in Table 3.1.

**Table 3.1** : Comparison between Quadrant bearing and Azimuth bearing.

Quadrant Bearing	Azimuth Bearing
N44°E	044°
N36°W	324°
S36°E	144°
S26°W	216°

Next, hand lenses is crucial in order to identify the hand specimens where the grains size or crystals size that build up the rocks can be observed. A hand lense with magnification of between 7 to 10 times is most convenient.

Besides that, sample bags is used to store rock specimens before its been processed into thin sections. Some important notes is wrote on sample bag such coordinates, type of rock, minerals content, level of weathering, date and time.

Measuring tape, the kind with short “roll-up” steel tape is very useful. A 3 m tape can be used to measure something from grain size to bed thickness. If the tape has black numbering with white background, it can be used as a scale for photographs purposed. A 30 m to 50 m “linen” tape also important for small surveys.

After that, a field notebook is also quite important, so it should have good quality “rain-proof” paper, with hard cover, good binding and should fit into pocket. A field notebook should have hard cover to provide suitable surface for writing and sketching with elastic band to keep pages flat.

Next, protractor is important to plot the bearing on map. Besides that, use pencils and erasers to write field data on field notebook and short note on map instead of stylus-type ink pens. Never record a data with pen because it will be difficult to erase if the data collected are wrong.


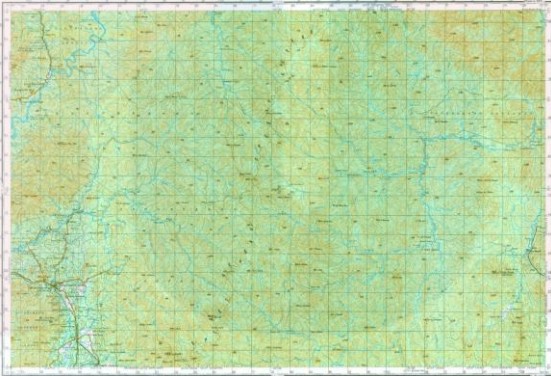

Hydrochloric Acid solution is important to differentiate different types of rocks or minerals such as limestone, quartz, calcite and dolomite. Goggles is a form of protective eyewear that protect the area surrounding the eyes. Goggles was used during hammering process to get rock specimen to prevent the rock chip from striking the eyes .

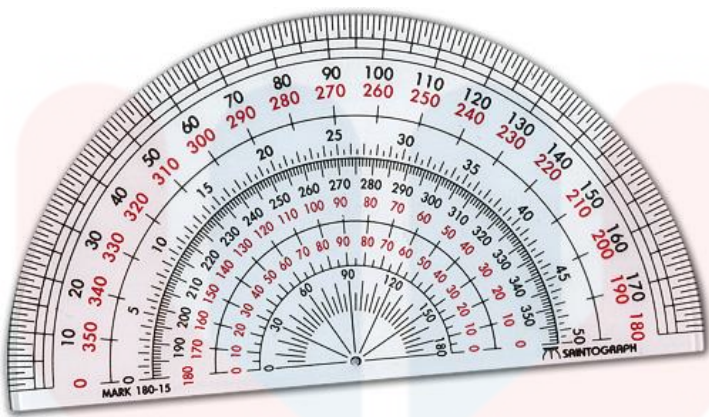


Next, for laboratory materials are Polarized microscope, Petrographic thin section and Thin Section Grinder were used to process rock samples in order to study about their minerals composition (for details steps, refer Table 3.3 in page 62). Besides that, to produce base map , ArcGIS 10.3 software was used, then some other software such as GeoRose software and the Stereonet software was used for structural analysis purpose.

**Table 3.2 :** The instruments and tools that needed for field work

No.	Figure of tools	Name
1	 <p data-bbox="842 703 1139 741">Source : Google Image</p>	Geological Hammer
2	 <p data-bbox="842 1330 1139 1368">Source : Google Image</p>	Portable Global Positioning System (GPS)
3	 <p data-bbox="842 1890 1139 1928">Source : Google Image</p>	Compass



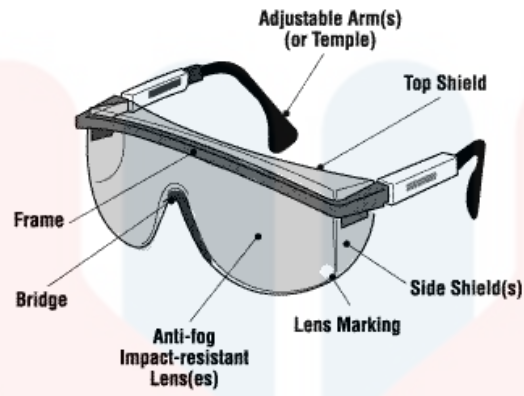
7	 <p>Source : Google Image</p>	<p>Hydrochloric Acid solution (HCL)</p>
8	 <p>Source : Google Image</p>	<p>Topographic map</p>
9	 <p>Source : Google Image</p>	<p>Scales</p>

<p>10</p>	 <p>Source : Google Image</p>	<p>Protractor</p>
<p>11</p>	 <p>Source : Google Image</p>	<p>Pencil and Eraser</p>
<p>12</p>	 <p>Source : Google Image</p>	<p>Chisels</p>



13	 <p>Source : Google Image</p>	Camera
14	 <p>Source : Google Image</p>	Binocular
15	 <p>Source : Google Image</p>	Notebook

16



Source : Google Image

Goggles

### 3.4 Field Studies

Fieldwork is crucial element in this research. To complete this research, all area of 25 km<sup>2</sup> within study area needed to be fully covered. During conducting fieldwork activities, one of the important soft skill is how to deals with other communities. At first, permission from the owner of the local area should be taken in order to access study area. Communicating with the residents of study area is essential to get any useful information regarding study area, such which part of study area is access able, how to access an area. The permission from the authorities such as police department also should be taken for safety purposes.

During this study, mostly of fieldwork activities take place only on weekend. There are two types of field studies that were carried out in order to finish this research successfully which are Geological Mapping and Geological Structure Mapping. The field studies including doing basic geological mapping for study area by finding the outcrops and geologic structures . All those outcrops and geologic structures were examined carefully and the in-situ data were gathered. Each of the localities were noted in field book, a few pictures of the outcrops and any geological structures are taken by using camera, sketches of each outcrop is done and geologic features were noted in field book. During this process, the base map acts as a guide in study area.

The traversing method is a surveying method used to cover study area. Traversing can also be used to map study areas in details where rocks are

well exposed. Few of traversing method used during run this research are road traversing, river traversing and ridge traversing. River or stream and ridge are the features that easily to identify and give excellent semi-continuous exposures. Besides that, waterfalls and stream junction also can be used as a position finding from its shape and direction of bends because it quite easy to observe on map. In the other hand, road traverses is a rapid reconnaissance survey of an unmapped area by move along tracks and road. Next, the other traverse method is by following contact.

The main objective of mapping activities in geology study is to locate and trace any contact between different rock formation and to show them on a map the position of their occurrence. When mapping in poorly exposed regions, method used are by indications of rock from soils as weathered rock will eventually turn into soils, nature of vegetation guides, topography and geomorphology faetures, and structure or stratum contours.

During conducted the field work, sampling of rocks were taken. In this research, a quite number of samples were taken in order to gather any related data regarding study area which is about types of rocks and the formation that build up study area. The sample of rocks should be fresh and not fully weathered in order to gain an accurate data. All of those samples were placed in the sealed plastic bags. The information regarding the hand specimens such as the locations, physical appearance of the samples were wrote on the plastics bags. All the locations where samples were taken is marked in GPS as well.

### 3.5 Laboratory Investigation

In order to conclude this study, two types of laboratory analysis will be used, they are petrographic analysis and structural analysis. Petrography analysis is the analysis that describes the minerals content and textural of the rock.

The analysis starts with describing fresh hand specimen that was taken from the outcrop during field work activities. The sample is analysed and described based on physical properties such as colour, minerals content, textures, and its grains size. Next, thin section was done to get detailed information regarding the microscopic properties of rock samples. The analysis shows micro-texture, structures of rock, optical properties, morphology properties of minerals such grains size, grains shape, cleavages, fractures, inclusions, intergrowths and some alteration products if present. In order to make thin section for the rock sample, an instrument called petrographic thin (refer figure 3.5) section was used. The petrography of the rock samples were analysed and all data that gained from this laboratory work is then presented in report.

For structural analysis, all data from field work activities such strike and dip reading, orientation of fractures and joints were analysed and process with the GeoRose and Stereonet software in order to determine the main directions and orientations of forces that take place in the study area.





## Preparation for making a thin section





Thin section making equipment are the slab saw or Petro-cut machine (refer Figure 3.3), the grinder, the trim saw or PetroTrim (refer Figure 3.4), the cut-off saw or Petro-thin machine (Figure 3.5), and the lap wheels.

Firstly, there should be a glass slide that had been frosted to flatten and roughen at one of its surface to make sure the epoxy can bind well, it can be done using grinder. Next, hand specimen is then cut using the slab saw. The slab is then trimmed using trim saw in order to reduce the size of the slab to fit thin section glass. Next, the sample is grinded to a flat surface by using a diamond abrasion with distilled water. A 400-mesh diamond plate will be used for the final grinding while 600 mesh to 1200 mesh can be used to polish the surface of thin section. An epoxy resin such as Buehler resin and hardener is prepared for mounting with ratio 2:1. During the mixing process, air bubbles are ensures not entering the epoxy and the epoxy is place on the glass slide . After that, the rock's chip is then attached into rosted side of glass slide. The thin section is left for one day to ensure that rock's chip is fully attach to the slide. Next, sample that has been mounted on the glass slide will be grind again by using hand or by wheel using diamond impregnated metal plate or wheel. The type of 80 to 200 grit size will be used until the thickness of the sample is about the size of glass slide. Then, a 400 to 600 diamond grit is used to lap and get final thickness. The thickness of the thin section can be checked by using a petrographic microscope. The thin section is considered finish if the all minerals can be

observed clearly under Thin Section Viewer (refer Figure 3.6) and petrographic microscope. The common thickness for the sample of petrographic thin section is 30 microns or less. Table 3.3 shows step by step to create a thin section with help of figures.

**Table 3.3** : The flow for thin section processes

FIGURE	EXPLANATION
	<p>The hand specimen is collected during field work or site visit, only fresh rock is chosen.</p>
	<p>The fresh hand specimen is then cut into smaller size (slab) using petro-cut machine.</p>
	<p>The rock that had been cut into smaller piece is then recut into rectangular shape in order to fit with glass slide.</p>
	<p>Then, the slab is glued into the glass slide with epoxy and resin that had been prepared at the first place, then the slide is left for one night.</p>

	<p>After one night, the slab is cut-off using petro-thin close to the slide approximately 2 mm, after that, the thickness is reduced using thin section grinder until the thickness less than 0.2 mm.</p>
	<p>Next, the slide is then lapping by hand on a glass plate with 600 grit carborundum followed by 1000 grit prior to polish the slide.</p>
	<p>The slide is then inspected using thin section viewer to make sure that the minerals can be observed under light microscope.</p>
	<p>The example of finished thin section.</p>





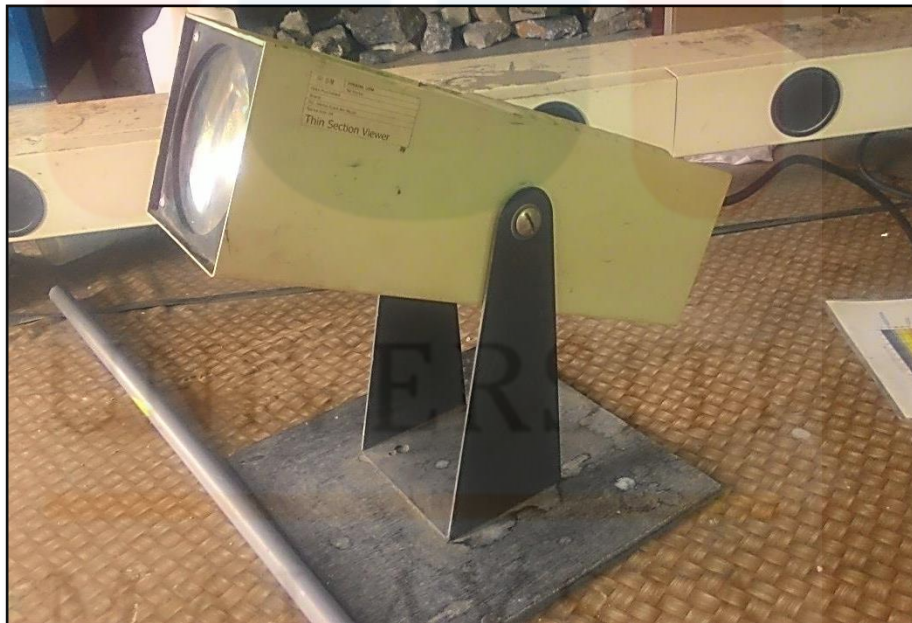
**Figure 3.3 :** The Petro-cut machine, to cut the rock into slab.



**Figure 3.4 :**The PetroTrim, to cut the slab into suitable size for slide.



**Figure 3.5 :** The Petro-thin machine, used for cutting off slab and reducing thickness of slab.



**Figure 3.6 :** The Thin Section viewer, used to view slide after lapping process.

KELANTAN

### 3.6 Data Analysis And Interpretation

The data both from field work and laboratory work that have been collected, need to be analysed. All data that can be gathered from the geological mapping activities are structural geology, geomorphology, lithology, strike and dip, joints and fractures, landform, drainage pattern and water catchment. The lithology data can be used to produce lithology boundary map, cross-section, and the distribution of lithology within study area.

Next, the data from strike and dip, joints and fractures reading can be used to interpret the direction of force that acting on study area as well as the deformation processes that occurs in study area by using GeoRose and Stereonet software. All those field work data is crucial to produce a geological map.

The petrography data from thin sections of hand specimens is interpreted and analysed as well. The petrography data can be used to determine the minerals content of the rock, and eventually give the specific name for the rocks. All the data from field work and laboratory work is gathered and then presented in the report.

### 3.3.4 Report Writing

This is the last step for the final year project assessment. The report was wrote according to the topic and sub-topic that already provided by the faculty. In this report, all the finding, data, and information regarding this research were presented carefully. The report was wrote based on the standard of scientific report writing. This report is submitted with the hope that this study can fill the gaps of the past researches and fulfils the objectives of this study.

## CHAPTER 4

### GENERAL GEOLOGY

#### 4.1 Introduction

General geology is a study about all dimensions of geology and science that regarding the Earth. The field of geology including formation of the Solar System, Universe, rocks and minerals, the composition, structure, physical properties and the history of Earth's components as well as the processes that shaped them. From general geology, all hazards that caused by all processes that occurs on and within the Earth such as landslide, earthquake, sink hole and volcanism can be successfully studied. All those knowledge can be used to save many human souls and preserved other spheres on Earth.

In this chapter, its describe and gave information regarding the study area such as geomorphology, structural geology, stratigraphy, historical geology. All these information are important for researchers, mainly Geologist to know about the geologic processes that take place in study area.

Geomorphology, is the Earth's science that focus on the surface of a planet and all related processes that responsible toward its formation. Its study about their origin and evolutions of topographic and bathymetric features resulting from physical, biological and chemical processes that occurs at or near the Earth's surface. The examples of geomorphology is mountain range, valleys, and deep sedimentary basins.

Structural geology is the study about deformation processes on and within Earth's crust including the materials and the mechanics that lead to all deformations processes. Next, historical geology is a study that uses all knowledge, techniques and principles of geology to reconstruct geologic processes in an order or sequences to fully understand all the processes that happened during ancient time.

Stratigraphy is a study that focus about rock strata and stratification. There two types stratigraphy which are lithostratigraphy and biostratigraphy. In this research, it focused on lithostratigraphy.

Historical geology is study about geologic events or processes that change this Earth's surface and subsurface with the help of structural geology, stratigraphy and paleontology in order to arrange the sequences of these events.

The study area is located in rural area. It is about 40 km from Gua Musang main town to the Pos Blau village. The study area can be accessed through paved road no.185 Lojing-Cameron Highland highway and the only road that connected Pos Blau to Gunung Ayam is unpaved road. The road condition is very poor and can be accessed using motorcycle, off-road vehicles and 4x4 trucks such as Hilux.

Next, study area is mostly covered by palm plantation followed by rubber plantation. Just a small area within the study area is covered by tropical rain forest. The wild animal can be found within the study area are snakes, wild boars, elephants and many more. Within the study area, there a few settlements can be found such Liziz Plantation and Pos Blau plantations.

The methods that had been used in order to map the study area is using river traverse and follow the landforms.

## **4.2 Geomorphology**

Geomorphology is study about Earth's shape or Earth's landform and its processes that related to the origin and the evolution of the Earth's shape itself. Landform is defined as any recognizable, naturally formed feature of the solid surface on the Earth which have a characteristic shape with large and small features such as plateaus, mountain, plains and valleys, hills, canyons, bays, mid-ocean ridges and volcanoes. There are two categories of landform, they are :

1. Physical attributes.
2. Gross physical features.

The parameter for physical attributes such as slope, elevation, orientation, and soil type while for gross physical features such mountains, hills, ridges, cliffs, lakes, as well as other kinds of inland and oceanic water bodies.

### **4.2.1 Topography**

Topography is defined as detailed description of the surface features of land in a region. Generally, it concerned with the position and elevation of its natural as well as man-made features of land.

The value of contour line on topographic map represents the actual elevation of an area. Based on the contour lines from topographic map, the location of slopes, depressions, ridges, cliffs, height of mountains and hills, and other topographical features can be determined. As example, evenly spaced contours lines indicates uniform slope while widely spaced contours indicate a gentle slope. Widely spaced contours lines at the top of a hill indicate flat hilltop. On the other hand, close together contours lines indicate steep slope, wall or cliff and close together r contours at the top of a hill indicate a pointed hilltop. Crossing or touching contours indicate overhanging cliff. Other than that, jagged, rough contours indicate large outcrops of rocks, cliffs, and fractured areas. The “V” shape contours indicate stream beds and narrow valleys with the point of the “V” pointing uphill or upstream while “U” shape contours indicate ridges with the bottom of the “U” pointing down the ridge.

For the study area (refer Map 4.1), the natural features that made up the topography in this area are mountains, hills and valleys. The highest elevation is 600 m and the lowest elevation is 160 m. The North-West part of the study area, the elevation range is from 180 m to 440 m with very steep elevation and the elevation on South-West part range from 160 m to 300 m. Meanwhile, elevation on the North-East and South-East part range from 160 m to 600 m with flat elevation. Based on the map in Map 4.1 . Gunung Ayam located in elevation between 360 m to 600 m at the Western part of map.

The three dimensional map can be observed in Map 4.2. Five types of topographic unit which classifies based on the mean elevation above the sea level in meter is shown in Table 4.1 (Nazaruddin, D. A., et al., 2014).



**Table 4.1** : The topographic unit based on mean elevations

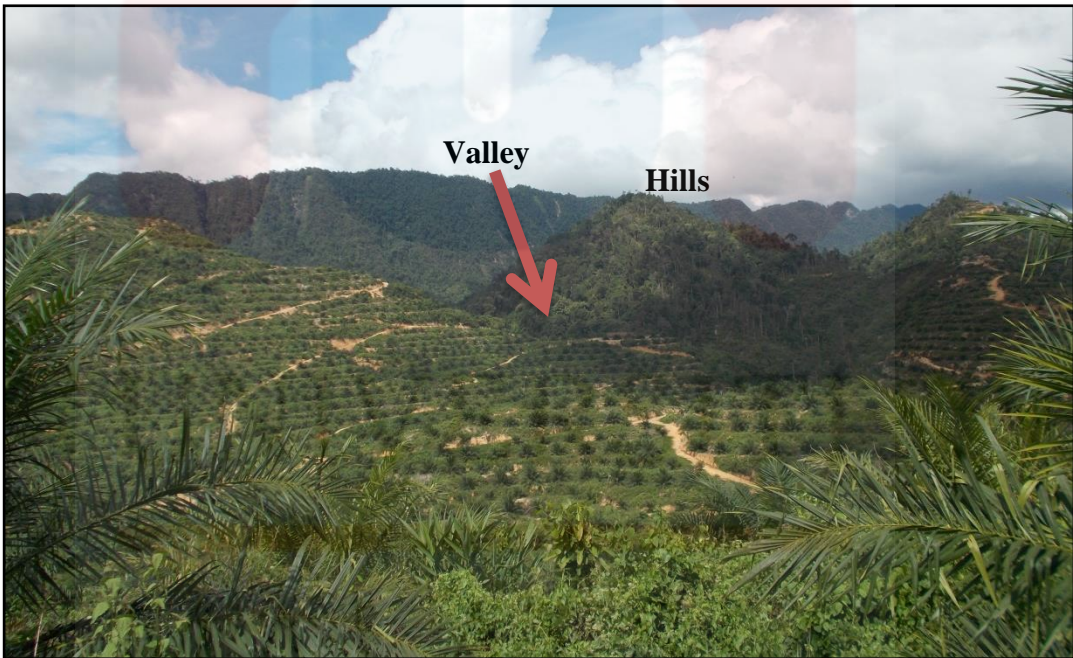
<b>Class</b>	<b>Topographic Unit</b>	<b>Mean Elevation above sea level in meter (m)</b>
1	Low Lying	<15
2	Rolling	16-30
3	Undulating	31-75
4	Hilly	76-300
5	Mountainous	>301

(Nazaruddin, D. A., et al., 2014).

Figure 4.1 show the appearance of cascade area in the valley while in Figure 4.2, there are two type of landform can be observed which are hills and valleys. Mountainous area can be observed in Figure 4.3. The mountain in study area is known as Gunung Ayam. The slope of Gunung Ayam is almost 90° making it impossible to reach top of mountain. The only road to reach the top is located at the Northern Part of Gunung Ayam. In Figure 4.4, fluvial area can be observed. It is located near with Sungai Berok at bedded limestone area. The fluvial contain of rock particles range from clay to pebbles that eroded from the surrounding road and transported by water. Map 4.4 shows the landform that can be observed in study area which contains mountain, hills and its undulating , valleys and fluvial.



**Figure 4.1** : The cascade area at valley.



**Figure 4.2** : Hills and valley in study area.

MALAYSIA  
KELANTAN

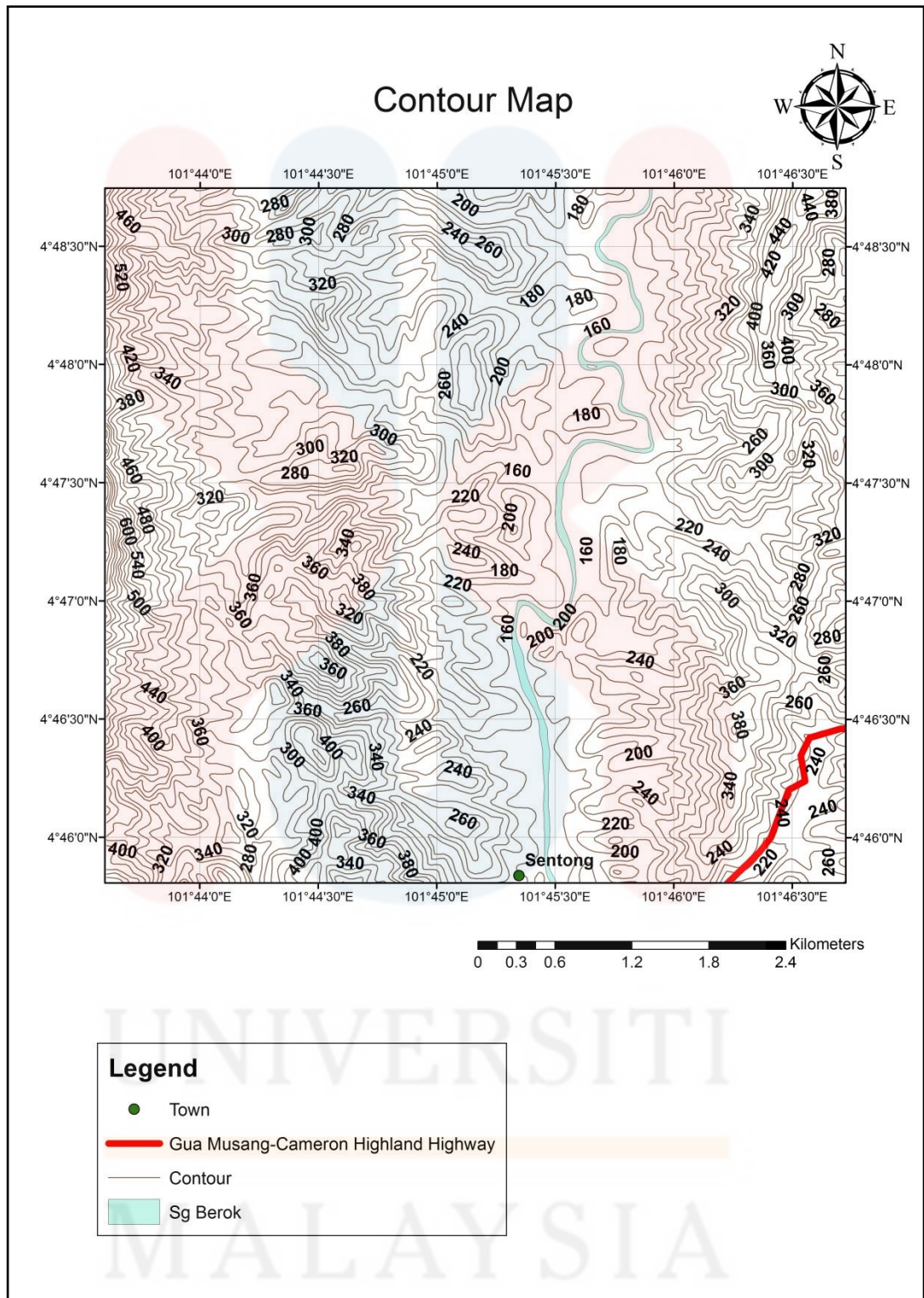


**Figure 4.3 :** The mountain area, which is Gunung Ayam.

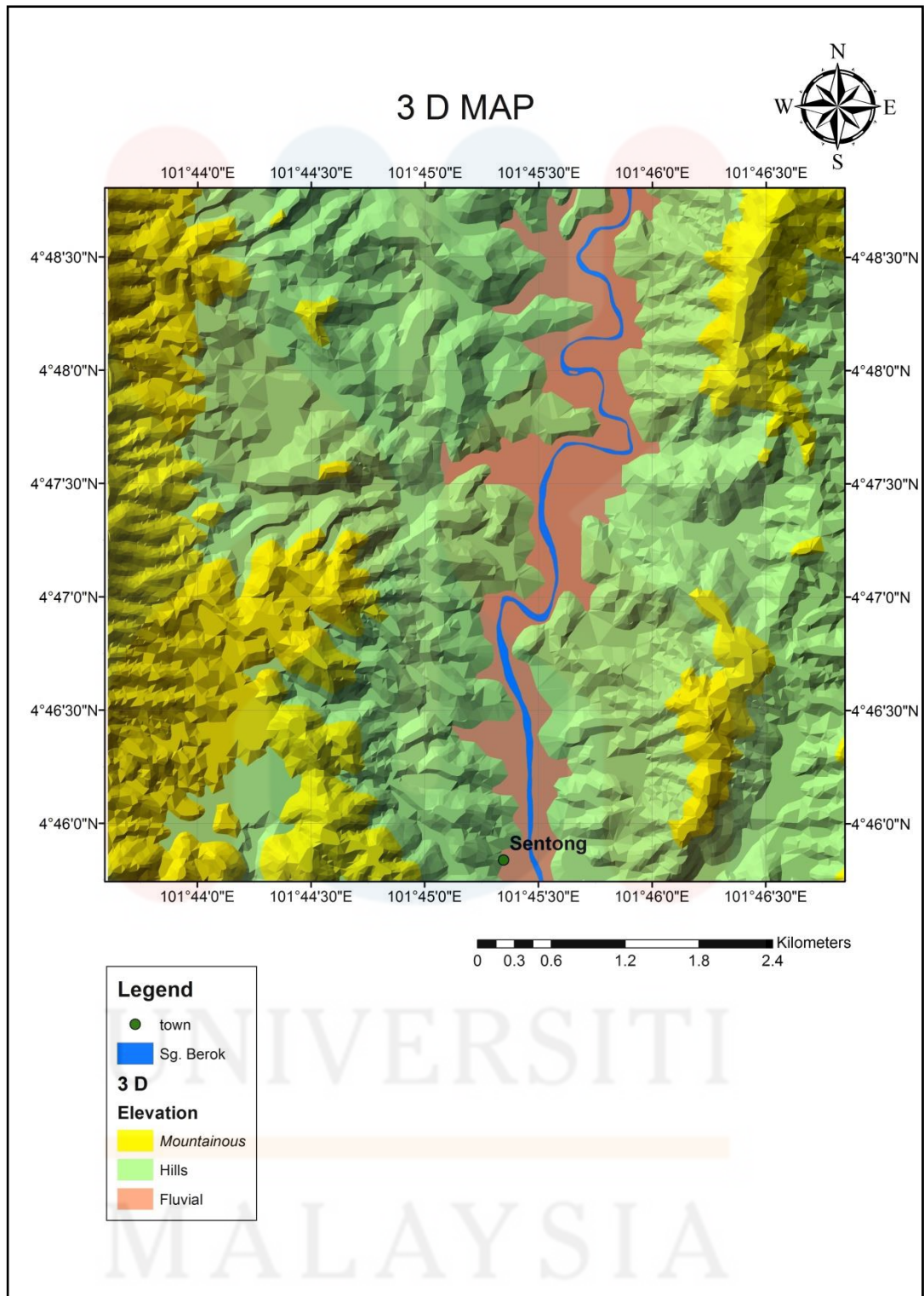


**Figure 4.4 :** Fluvial area in oil palm estate.

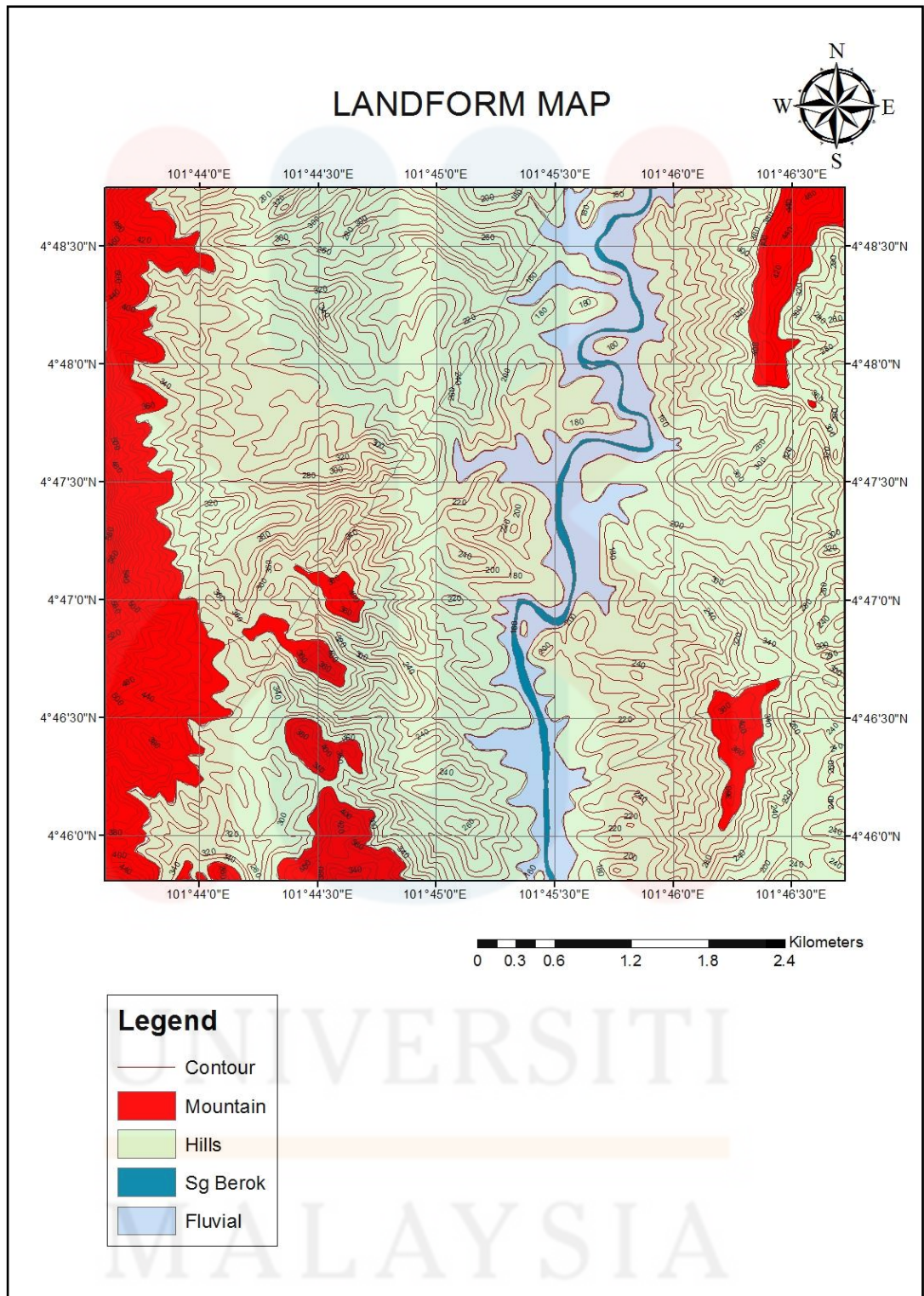
MALAYSIA  
KELANTAN



**Map 4.1 :** The contour map for study area



**Map 4.2 :** 3 Dimensional map of the study area, showing that majority of the study area covered by undulating



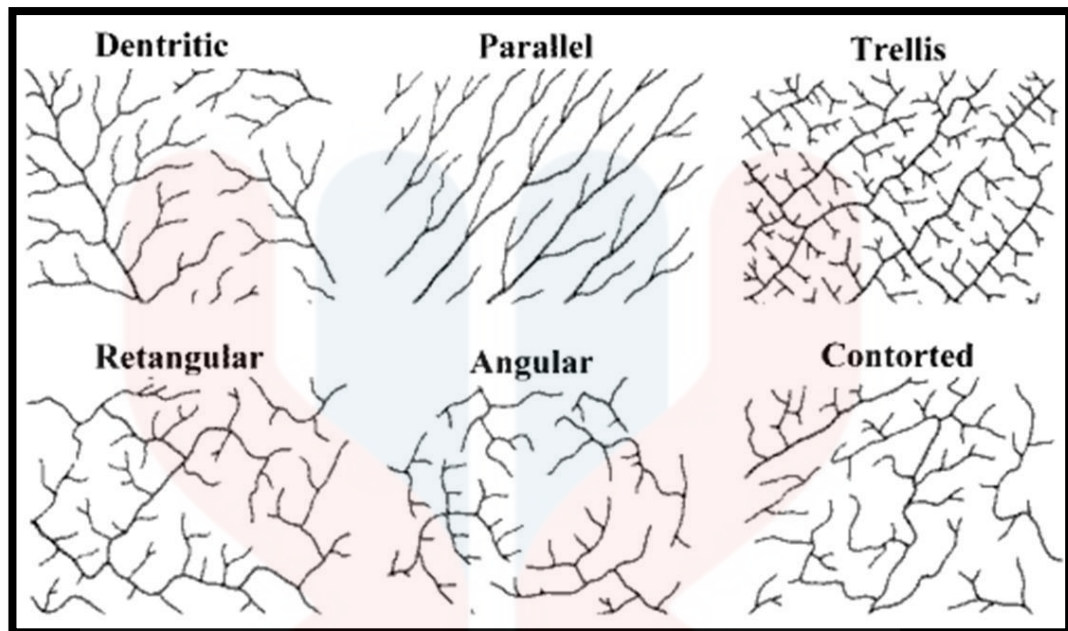
**Map 4.3 :** The landform map of study area, consist of fluvial, hilly and mountainous.

#### 4.2.2 Drainage System

Drainage system is defined as water bodies that have pattern formed by rivers, streams and lake within the area. The drainage pattern is controlled by types of lithology and geologic structure of that particular area.

River system, also well known as drainage system are pattern that formed by the rivers, streams, lakes and all the Earth's surface water bodies in a particular drainage basin. The drainage pattern is controlled by topography and the geology of the particular area whether dominated by hard and highly resistant rock such as granite and limestone or soft and low resistant rock such mudstone and siltstone. Drainage pattern is drainages that tend to develop along weak zone where rocks are easily eroded. From the drainage pattern, it can aid in identification of rock type, recharge area and potential condition of the area.

There are several types of drainage patterns classified as dendritic, parallel, trellis, rectangular, angular and contorted as shown in Figure 4.5 (Thornbury, 1969). The main river in the study area is Sungai Berok as shown in Figure 4.6. A few small stream also can be observed in study area as shown in figure 4.7. The other small rivers are Sungai Ohr, Sungai Sungkai, Sungai Jenat, Sungai Seloh, Sungai Jenut, Sungai Tawar, Sungai Lambok, Sungai Rawing, Sungai Sekor, Sungai Tai, Sungai Salak and Sungai Lasau. The appearance of cascade area ( Figure 4.8) in one of the valleys in study area.



**Figure 4.5 :** Types of drainage pattern (Thornbury, 1969)

Within study area, drainage pattern is coarse sub-dendritic and parallel as shown in Map 4.4. From these drainage pattern, it can be interpreted that this area generally has been affected by structural control such faults.

The first pattern is sub-dendritic pattern that have a tree branches like pattern. This pattern composed of many irregular branching that contributes to a main stream. This pattern of flow of stream and river develops in an area which composed of rocks with a uniform structure and on the hard rock that have no structural shape. This pattern usually forms at very steep slopes and join the main stream at acute angle. Dendritic system pattern forms a V-shaped valleys and the type of rock must be impervious and non-porous. Example of dendritic pattern in the study area is Sungai Sekor

The second pattern is parallel pattern and the direction taken by the river is depending on the slope of that area. Parallel pattern is pattern with regular spaced and more or less parallel main stream that join together. It



forms when the slope is uniformly resistant and where faults, monoclines and isoclines spaced. Parallel drainage patterns may develop in area that had steep slopes. This pattern of drainage system was flowing on the same direction because of the steepness of the slopes in the area. Examples of parallel pattern in the study area are Sungai Sungkai, Sungai Jenat, Sungai Seloh, Sungai Jenut.

Study area consist a few of minor watershed. Watershed is a place or basin of land where all water from different rivers or streams accumulated in one place. Map 4.5 showing the watershed map for study area.



**Figure 4.6 :** The main river in study area, Sungai Berok.

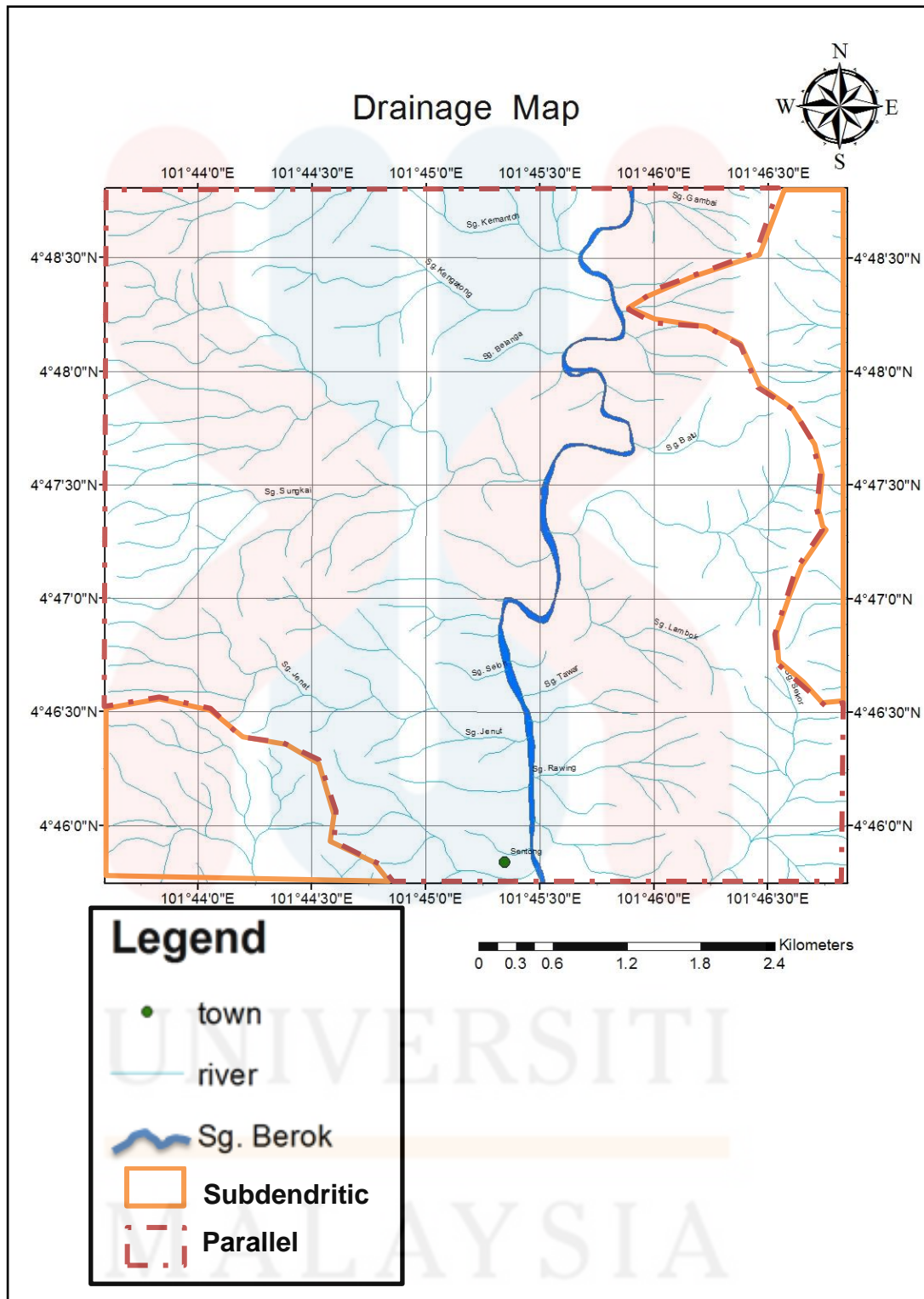


**Figure 4.7 :** The small stream that has clear water in study area.

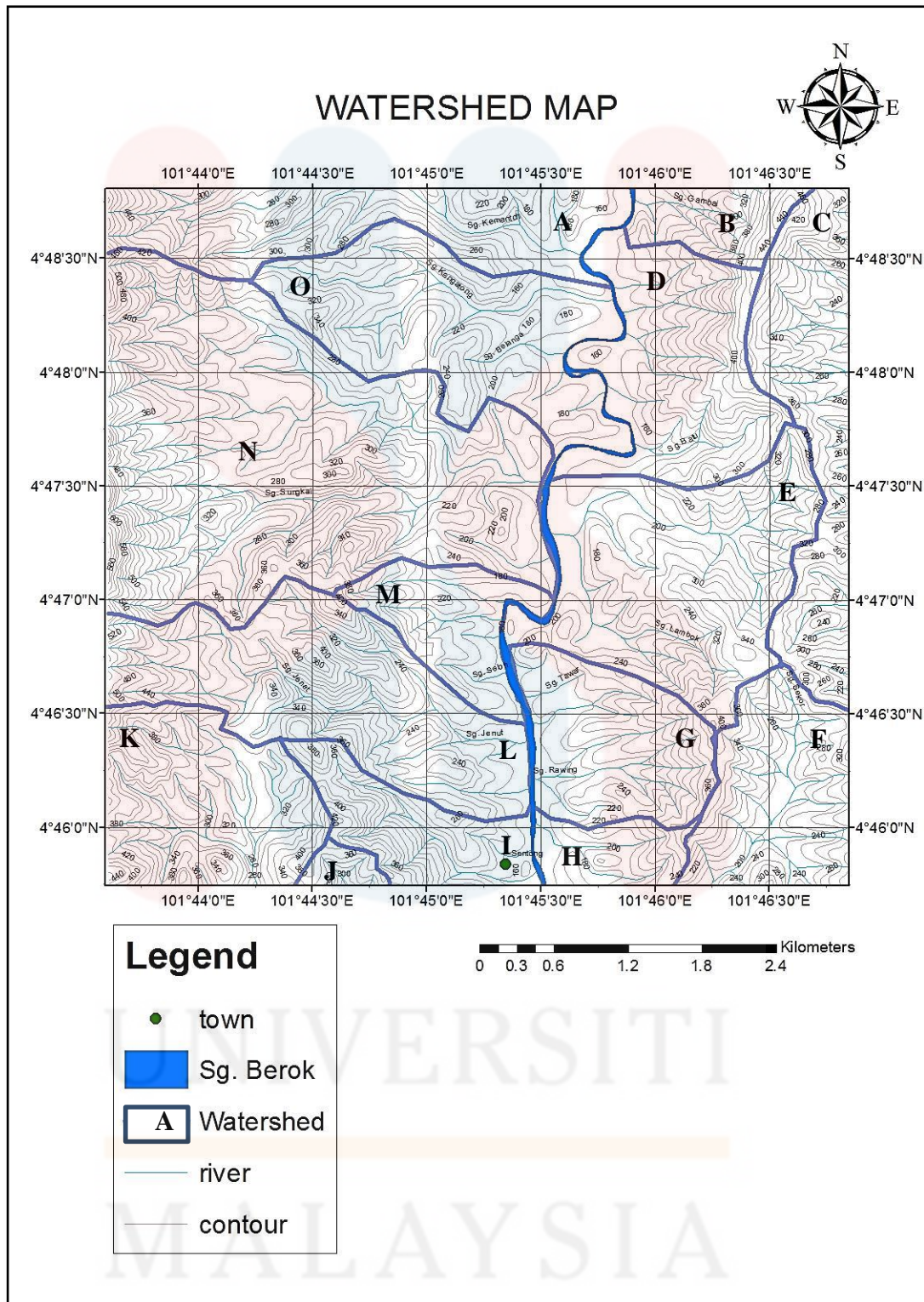


**Figure 4.8 :** The presence of cascade in study area.

MALAYSIA  
KELANTAN



**Map 4.4 :** The drainage pattern of study area is coarse subdendritic and parallel.



**Map 4.5 :** The watershed of the study area

### 4.2.3 Weathering Process

Weathering is any external process of Earth. Weathering is the physical breakdown and chemical alteration of rocks at or near Earth's surface. Weathering occurs when rock is mechanically fragmented or chemically altered. Weathering may occur in the original source area where bedrock is exposed or in rock material that have been eroded, transported and deposited thousands of kilometres away from their original source area. Weathering processes is an in-situ and a degradational process. The weathering agents are water, wind, gravity and glacier. For study area, the weathering agents are limited to water, wind and gravity.

There are a few factors that affecting the rate of weathering which are time, climate, area of exposure, particle properties and mineral composition. Malaysia is located at the Southeast Asia and within the equatorial region on Earth. It's has tropical rainforest climate and tropical temperature remains relatively constant throughout the year and seasonal variations are dominated by precipitation. Tropical rainforests technically do not have dry or wet seasons, since their rainfall is equally distributed through the year.

Rocks can be classified on the basis of its degree of weathering. This type of rock classification can gives tells about the stability of the rock mass. It can be done by observing on the rock condition. Based on Paul, there are seven grades of rocks which are : Fresh, Faintly weathered, Slightly weathered, Moderately weathered, Highly weathered, Completely weathered, Residual soil

**Table 4.2 : Weathering grade classification**

<b>Term</b>	<b>Description</b>	<b>Grade</b>
<b>Fresh</b>	No visible sign of material weathering	IA
<b>Faintly weathered</b>	Discoloration on major discontinuity surface.	IB
<b>Slightly weathered</b>	Discoloration indicates weathering of rock material and discontinuity of surfaces. All the rock material may be discoloured by weathering and may be somewhat weaker than its fresh condition.	II
<b>Moderately weathered</b>	Less than half of the rock material is decomposed and disintegrates to soil. Fresh or discoloured rock is present either as a continuous frame work or as core stones	III
<b>Highly weathered</b>	More than half of the rock is decomposed and disintegrated to soil. Fresh or discoloured rock is present either as a discontinuous frame work or as core stones.	IV
<b>Completely weathered</b>	All rock material is decomposed and disintegrated to soil. The original mass structure is largely intact.	V
<b>Residual soil</b>	All rock material is converted to soil. The mass structure and material fabric are destroyed. There is a large change in volume, but the soil has not been significantly transported	VI

(Paul, 2006)

From the outcrops in study area, most of them have undergone weathering process and highest grade of weathering identified is grade five. Weathering of rock masses can become as a predisposing factor to slope instability. So, identification of weathering grade is crucially important since most of the outcrops in study area are located along the hill slope due to the agriculture activity. Rate of weathering process and break up of slope material related to the rates of mass movement and material erosion which gives shape to the slope. A slope is considered stable if its material strength exceeds the weathering processes and unstable if its materials are weaker than the weathering processes.

In study area, rocks are highly exposed due to the logging and plantation activity. This condition increases the rate of weathering for the rocks that located in this area. There are three types of weathering which are:

- a. Physical weathering
- b. Chemical weathering
- c. Biological weathering

## Physical Weathering

Physical weathering or mechanical weathering is usually caused by the effect of temperature on rock, causing it to break apart without changing their chemical properties. It also can be caused by the movement of the earth and the environment that can break apart rock formation. The causes of physical weathering in study area usually due to temperature, pressure, and other factor. In figure 4.9, it can clearly observed the tuff outcrop broke into small pieces.

There are many examples of physical weathering such as exfoliation (where rocks expand and crack as the overlying rocks are removed by erosion), pressure release, and thermal expansion. As the temperature change the rock will expand making crack on rock surface. The rock also can be crack due to the crystal growth from evaporated salty water.



**Figure 4.9 :** Physical weathering on tuff outcrop create smaller pieces rock fragment..



## Chemical Weathering

The chemical weathering is where the rocks had been breakdown by chemical mechanisms. It changes the chemical composition of the rock through carbonation, hydrolysis, oxidation and hydration , as well as biological agents such as acids produced by microbial and plant-root metabolism.

In study area, the main cause for chemical weathering is rain water and groundwater. The water will react with the mineral grains within the rock forming a new kind of minerals and soluble salts. A mineral containing very little oxygen may react with oxygen in the air, extracting oxygen atoms from the atmosphere and incorporating them into its own crystal structure, thus forming a different mineral. Acid rain will enhance this weathering process to its maximum point. As example, in karst area, the dissolution of the limestone by groundwater will create a cave or other karst features such pinnacle structures as shown in figure 4.10.



**Figure 4.10** : Chemical weathering on limestone outcrop forming pinnacles structures and fractures.

## Biological Weathering

Biological weathering is the disintegration of rock as a result of the action by the living organism such as the roots of the trees, microbes and the burrowing of animals. Lichens and mosses grow on essential bare rock surfaces and create a more humid chemical microenvironment. The growing plant roots can give stress on rock (refer figure 4.11). This process is slow but it strongly influences landscape formation. As seedling sprouting in a crevice and plant roots exert physical pressure as well as providing pathway for water and chemical infiltration.



**Figure 4.11 :** Biological weathering on sandstone outcrop, the root from the vegetation make crack on the outcrop.

#### 4.2.4 Mass Movement

##### Erosion

Erosion is the natural process that involves the removal of the land surface by the action of gravity. In Malaysia that constantly having rainfall throughout all the year, Tjia (1999) states that there are two types of erosion process which

1. By flowing of water
2. By ocean current

From the field observation at Gunung Ayam area there are two types of erosion which are :

- a. Rill erosion
- b. Sheet erosion

Rill erosion occurs when water moves or flow on land surface constantly through small streamlets. The example of this kind of erosion in study area shown in Figure 4.12.

Sheet erosion is the removal of the surface layers of soil by wind and water activity. It can be found in the estate area as the forest been removed by human activities as shown in Figure 4.13.



**Figure 4.12** : Rill erosion can be seen clearly (red arrow)



**Figure 4.13** : Sheet erosion on hill in study area (red arrow)

## Rock Fall

Rock fall is pieces or fragments of rock that loose or separated by sliding, falling in either vertical, sub-vertical cliff, due to the gravity forces. In study area, a rock fall can be observed besides the Gua Musang-Cameron Highland highway, refer Figure 4.14. in this figure, the size of rocks that fallen is 1 m to 1.5 m in diameter.



**Figure 4.14 :** The occurrence of rock fall on the sandstone outcrop besides the main road in study area.

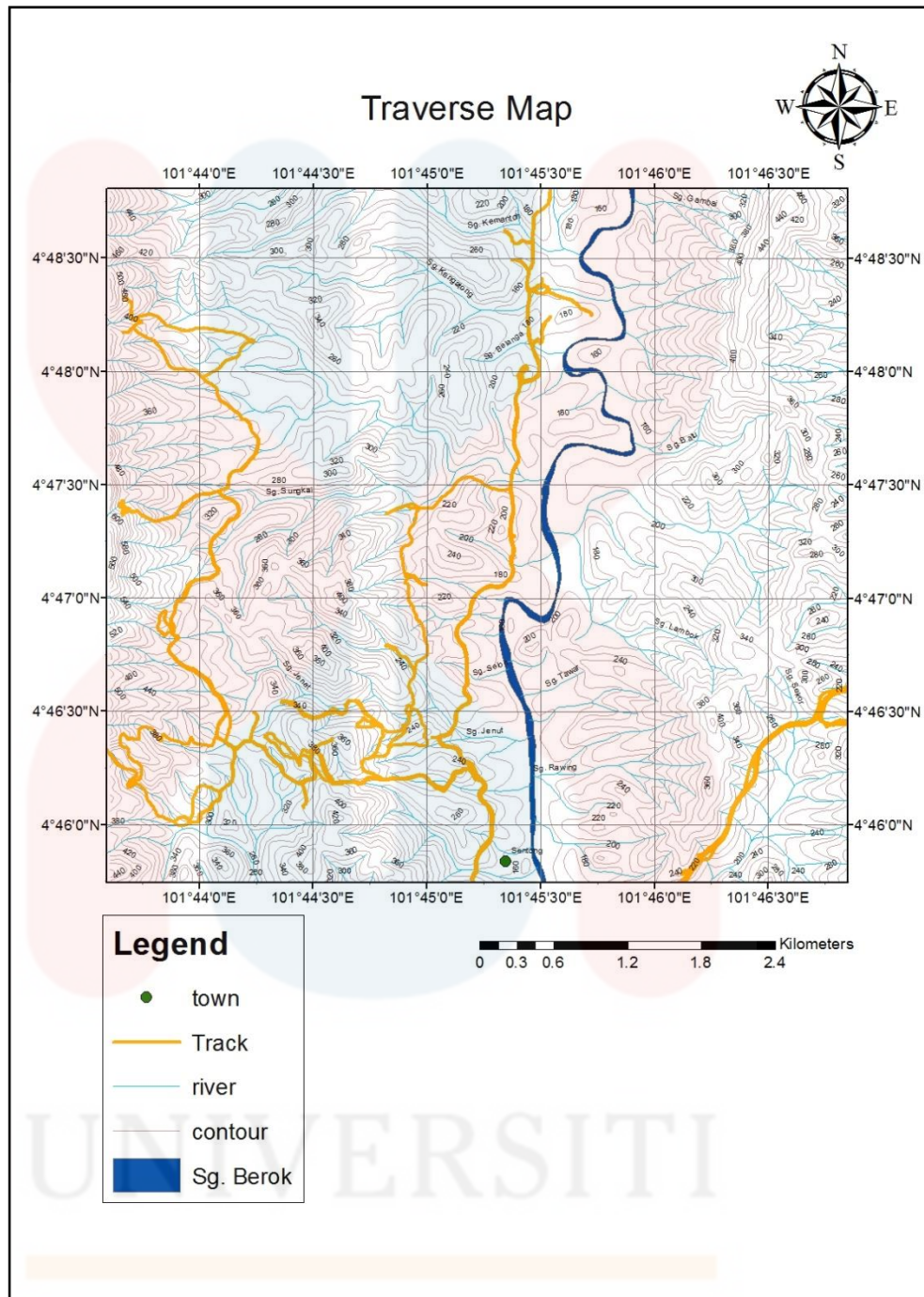
### 4.3 Field Observation and Mapping

Through field observation and mapping activities, a lot of data regarding the study area have been obtained. The method used for this purpose done by traversing throughout the study area to collect data such as outcrop samples, joints data, veins data, coordinates, strike and dip data, landforms and geological structure.

From all collected data, a detailed geological map can be created. Geological map gives information about rock distribution in of study area which gives idea about the formation and geological processes that happened in the past. From the understanding of the geological processes, it may give information about the surrounding lithology and prospect area that may contain valuable rock or economic mineral for mining.

Observation and identification of outcrop had been done during the field work activities. But in order to justify it, the rock samples is collected and petrographic analysis is carried out to obtain data regarding types of rocks and mineral composition . It is the process of identifying types of rocks from calculating the percentage of mineral in the rock by observing it under a microscope in the form of thin section.

Field mapping that has been done by traverse from South to North of study area, and from East to West the changes in lithology can be found. The traverse track shown in Map 4.6.



**Map 4.6 :** Traverse Map of Gunung Ayam, Lojing, Kelantan

#### 4.4 Lithology and Stratigraphy

Lithology is a brief information regarding the physical characteristics such as colours, textures, grain size and composition of rocks that can be observed by naked eyes at the outcrops, hand specimens.

Stratigraphy is a branch of geology that study about the order and relative position of strata and relate them with the geological time scale. it focus on the analysis or the order and position of strata of archaeological remains and the structure of a particular set of strata.

Lithostratigraphy is the study of strata to relate how the rock was formed which is defined and recognized on the basis of lithic characteristics and stratigraphic position.

The geological mapping and field investigation was done by traversing the accessible to semi-accessible area as shown in Map 4.4. For each type of rocks, it can be classified by their colour, mineral composition, texture, grain size and weathering grade characteristics. Lithostratigraphic unit for each type of rock can be determined from their petrography, mineralogy, paleontology, lateral variation and relationship with adjacent units whether by horizontal or vertical.

During the mapping process, several outcrops from different type of rocks have been identified which are sedimentary rock and igneous rock. There are four type of lithology of rocks in this study area which is limestone, conglomerate, breccia, shale, and tuff.



### 4.3.1 Limestone

Within the study area, there about 20-30% of the area that covered by limestone. It can be found abundantly along the Sungai Berok river in the middle of palm estate and rubber tree estate. The dimension of outcrop in term of height and width for the hand specimen outcrop are 50 m x 100 m. the limestone in the study area have undergone chemical weathering and biological weathering as shown in Figure 4.18. The grade of weathering is between IB to II, (refer table 4.2). In some place, brecciated limestone can be found in the study area. It can be interpreted that, brecciated limestone formed due to the tectonic force.

Limestone is a carbonate rock that formed commonly in shallow marine environment. The origin of limestone are the skeletal fragments of marine organisms such as corals, shells. It also can be formed due to the precipitation of calcium carbonate from the ocean water and lake.

Limestone commonly can be related to the karst topography due to their solubility toward acidic rains or groundwater.

Based on Nuraiteng Tee Abdullah (2009), the age of the limestone in this area is in Lower Triassic. The limestone in this area has underlain conglomerate and breccia lithology and over lain the chert with conformable contact.

Based on the hand specimen in Figure 4.15 and Figure 4.16 , the colour of the limestone is varies from light to dark grey. The textures of the limestone is coarse to fine grained. There also some bedded limestone that can be observed in study area as shown in Figure 4.19. The thickness of the

bed is varies from 5 cm to massive beds. Part of the limestone also contains calcite vein as shown in Figure 4.17.



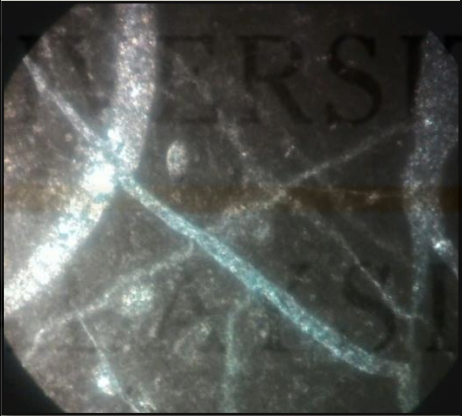
**Figure 4.15** : Hand specimen of coarse grain limestone.



**Figure 4.16** : Hand specimen of limestone with calcite vein.

Table 4.3 shows the details description of limestone thin section in study area.

**Table 4.3** : Description of limestone thin section of study area.

Location : Oil Palm Estate		Name of Rock: Limestone									
Rock Type : Sedimentary Rock											
Description of Mineralogy											
Composition of Mineral	Amount (%)	Description of Optical Mineralogy									
Calcite	45%	True colour is milky white.									
Groundmass (4G)	55%	Also, known as matrix and a fine grain mineral									
<b>Photo</b>											
	A B C D E F G H I J										
1											1
2											2
3											3
4											4
5											5
6											6
Figure 4.17: Plain Polarize (4x10)											



**Figure 4.18 :** The limestone outcrop that located in the banana tree and palm estate.



**Figure 4.19 :** The bedded limestone at the fluvial area in palm estate with hammer and person as the scale.

MALAYSIA  
UNIVERSITI  
KELANTAN

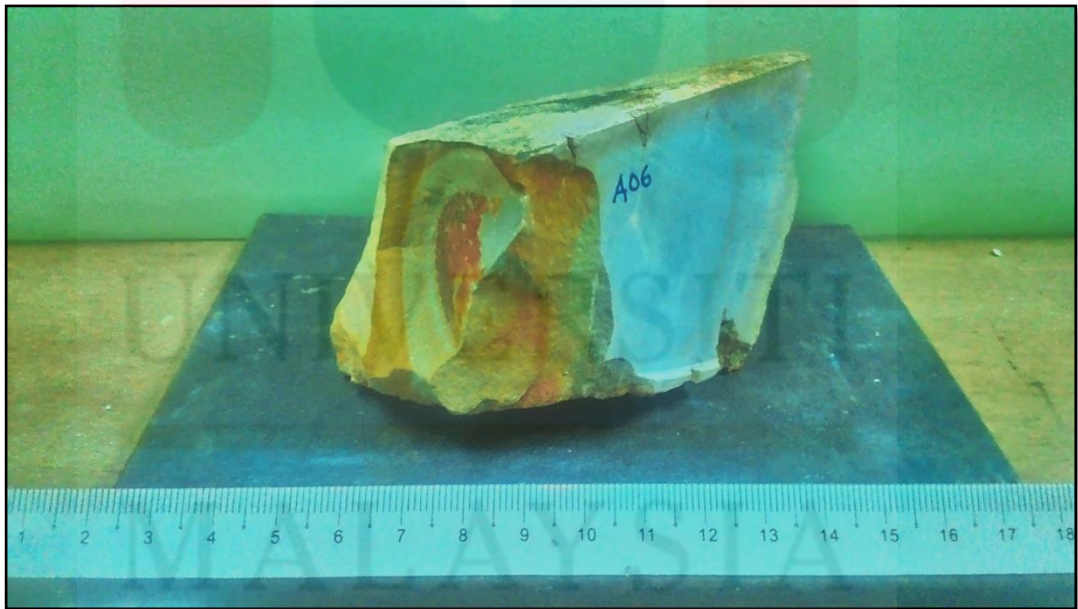
### 4.3.2 Sandstone.

There are a few spots that contain interbedded sandstone. The outcrop is weathered with level IV to level V grades. There are various type of sandstone which are, very coarse sandstone, coarse sandstone and fine grained sand stone as shown in hand specimen in Figure 4.21.

For very coarse grained sandstone, the observation is done at the site, the is no had specimen as the rock is highly weathered. From the observation, the sandstone is moderately well sorted. There also some iron oxide can be observed with naked eyes that had dark red-crown in colour. The outcrop of the very coarse grain sandstone that had been observed is 30 m height with 50 m width at the hills cutting outcrop. The sandstone is interbedded with fine grain shale. The thickness of the beds varies from a few millimetre to massive beds. There also some structure features can be observed such as fold and fault in sandstone bed as shown in Figure 4.20. Figure 4.22 shows that, the fine grain sandstone consist of very small quartz minerals. This sandstone is a arenite sandstone.



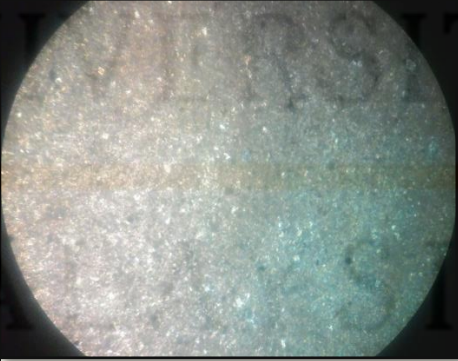
**Figure 4.20** : The coarse grain sandstone interbedded with shale ( dark grey ), there can be observe structure features such as open folds, drag fold and reverse fault with geological hammer and people as scale.



**Figure 4.21** : The hand specimen for medium to fine grain sandstone, with changes of colour due to weathering.

Table 4.4 shows the details description of fine grain sandstone thin section in study area.

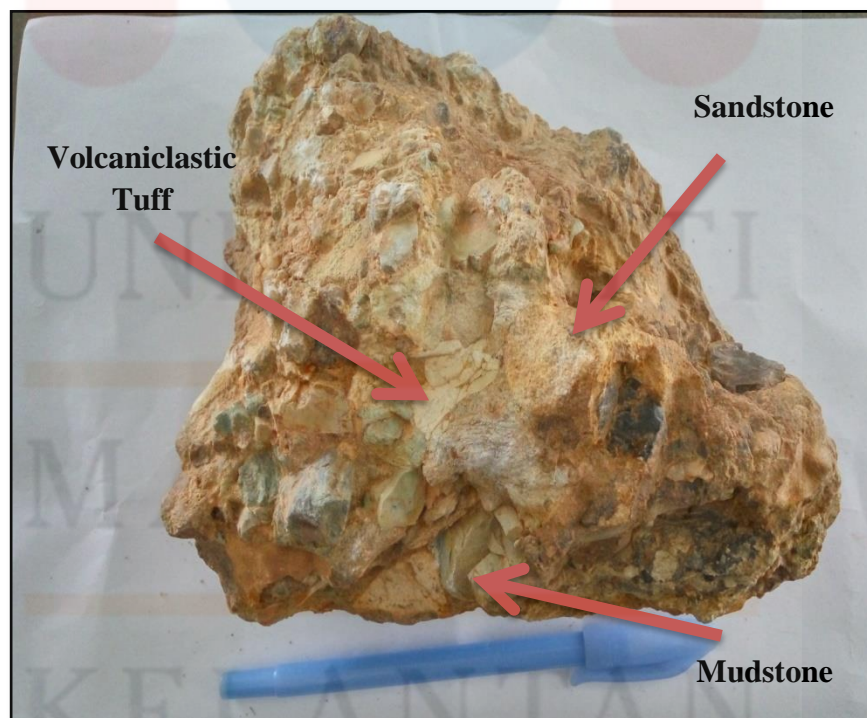
**Table 4.4 :** Description of fine grain sandstone thin section of study area.

Location : Road Cutting		Name of Rock: Sandstone									
Rock Type : Sedimentary Rock											
Description of Mineralogy											
Composition of Mineral	Amount (%)	Description of Optical Mineralogy									
Quartz	55%	True colour is milky white. The quartz size is small.									
Groundmass (4G)	45%	Also, known as matrix and a fine grain mineral									
<b>Photo</b>											
	A	B	C	D	E	F	G	H	I	J	
1											1
2											2
3											3
4											4
5											5
6											6
Figure 4.22: Plain Polarize (4x10)											

### 4.3.3 Conglomerate and Breccia

Conglomerate can be found at the foot of Gunung Ayam and its surrounding in 3 to 5 km radius. There can be found conglomerate interbedded with shale with gradational contact at the foot of Gunung Ayam.

The clasts of the conglomerate varies in size and parent rock as shown in Figure 4.23 and Figure 4.24. The range of clast size is from 5 mm to more than 200 mm. The conglomerate of Gunung Ayam is clast-supported. The parent rock for the conglomerate is metasedimentary rock. The clasts of conglomerate consist of chert, quartzite, schist, volcanic clastic tuff, siltstone and sandstone. The depositional of the conglomerate is meandering river environment. The outcrop of conglomerate can be observed in Figure 4.25.



**Figure 4.23** : The hand specimen of the conglomerate with pen as the scale.

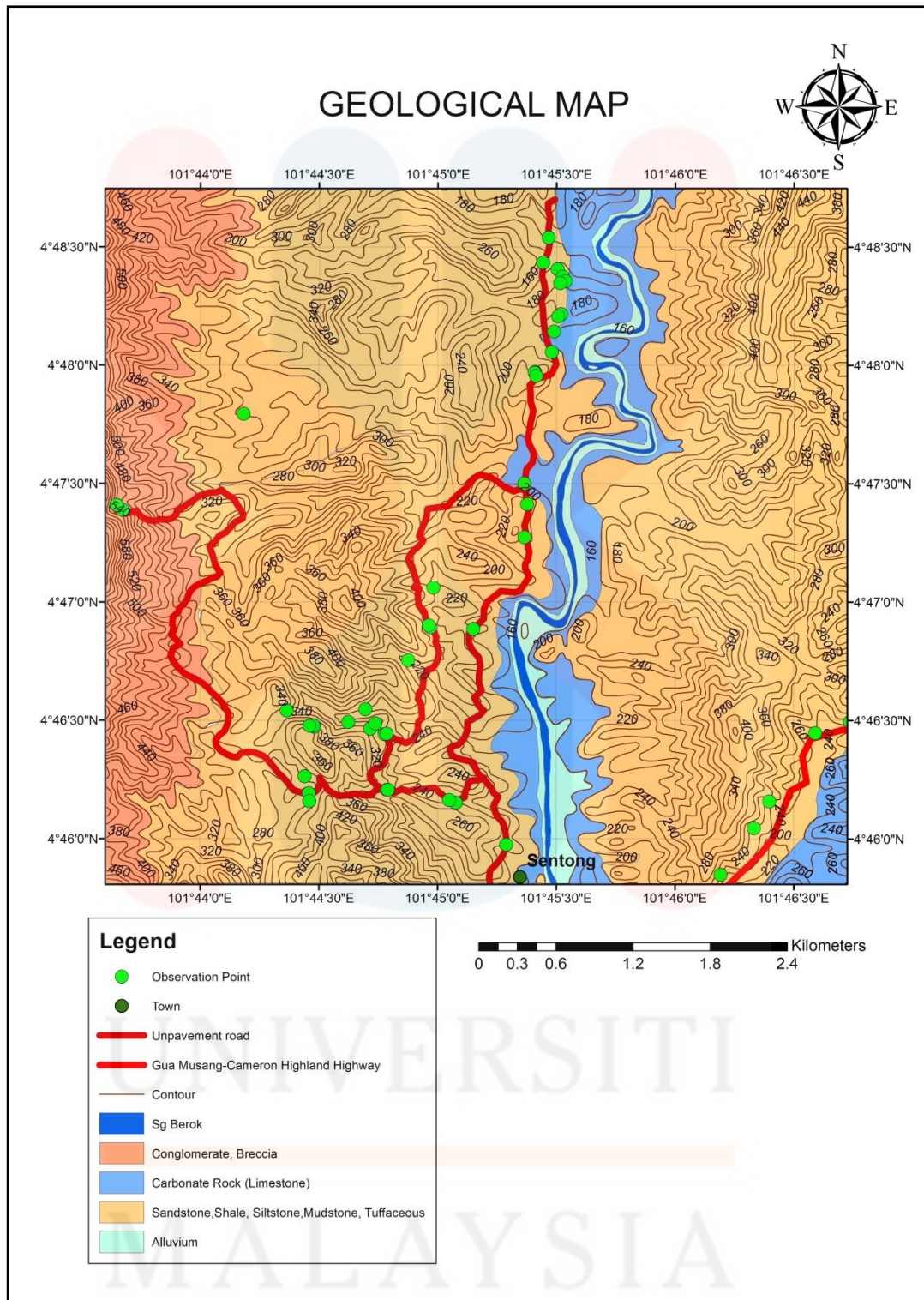




**Figure 4.24 :** The conglomerate with clasts range from 5 mm to 30 mm, GPS act as scale.


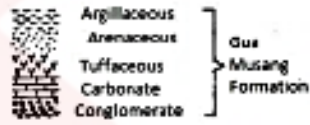
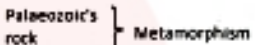


**Figure 4.25 :** The conglomerate outcrop at foot of Gunung Ayam near waterfall with clasts range from 50 mm to 500 mm, people as scale.



**Map 4.7 :** The Geological map of study area with observation points.

### Stratigraphic Column of Study Area

ERA	PERIOD	FORMATION or ROCK UNIT	LITHOLOGY
Quaternary	Recent	Alluvium	Sediment
Mesozoic	Cretaceous		
	Jurassic		
	Triassic		
	Permian		
	Carbonaceous		Palaeozoic's rock } Metamorphism
	Devonian		
	Silurian		
	Ordovician		

**Figure 4.26** : The stratigraphic unit (after Abdul Rahim Samsudin, Kamal Roslan Mohamad, Ibrahim Abdullah and Abdul Ghani Rafek, 1994)

## 4.5 Structural Geology

General structural geology in the research area is showing same tectonic pattern with Peninsular Malaysia. Past researches show that rocks in study area have undergone more than one episode of deformation where the force action toward study area region has produced obvious structure.

The research area is consisting of 3 types of structure which are normal depositional structures, depositional structures of limestone and post-depositional structures. Normal depositional structures that are formed during the deposition process of the sediment such as bedding and lamination. This structures can be observed on sandstones and shale outcrops within study area. For post-depositional structures, the evidences can be observed on the limestone outcrops that located along Sg.Berok area.

In order to gain the data regarding the structural geology within study area, two type of methods had been used which are using :

1. Indirect method.
2. Direct method.

The indirect method is done by observed the lineaments using satellite imaginary, topographic map, contours patterns and any related materials. For direct method, data is gathered by doing fieldwork and field observation in study area. The structure geology can be observed during fieldwork as example by observed geomorphology such as trigular facet, rivers and hills. Data also come from the measurement during field work such as strike and dip, lineation on rock, axial lines as well as foliation on metamorphic rock.

All data is then processed using Geo Rose software to produce Rose Diagram and Stereonet software. The data that has been analysed will show the direction of main forces and shear tension that take place in study area during ancient time forming all those structures and landform.

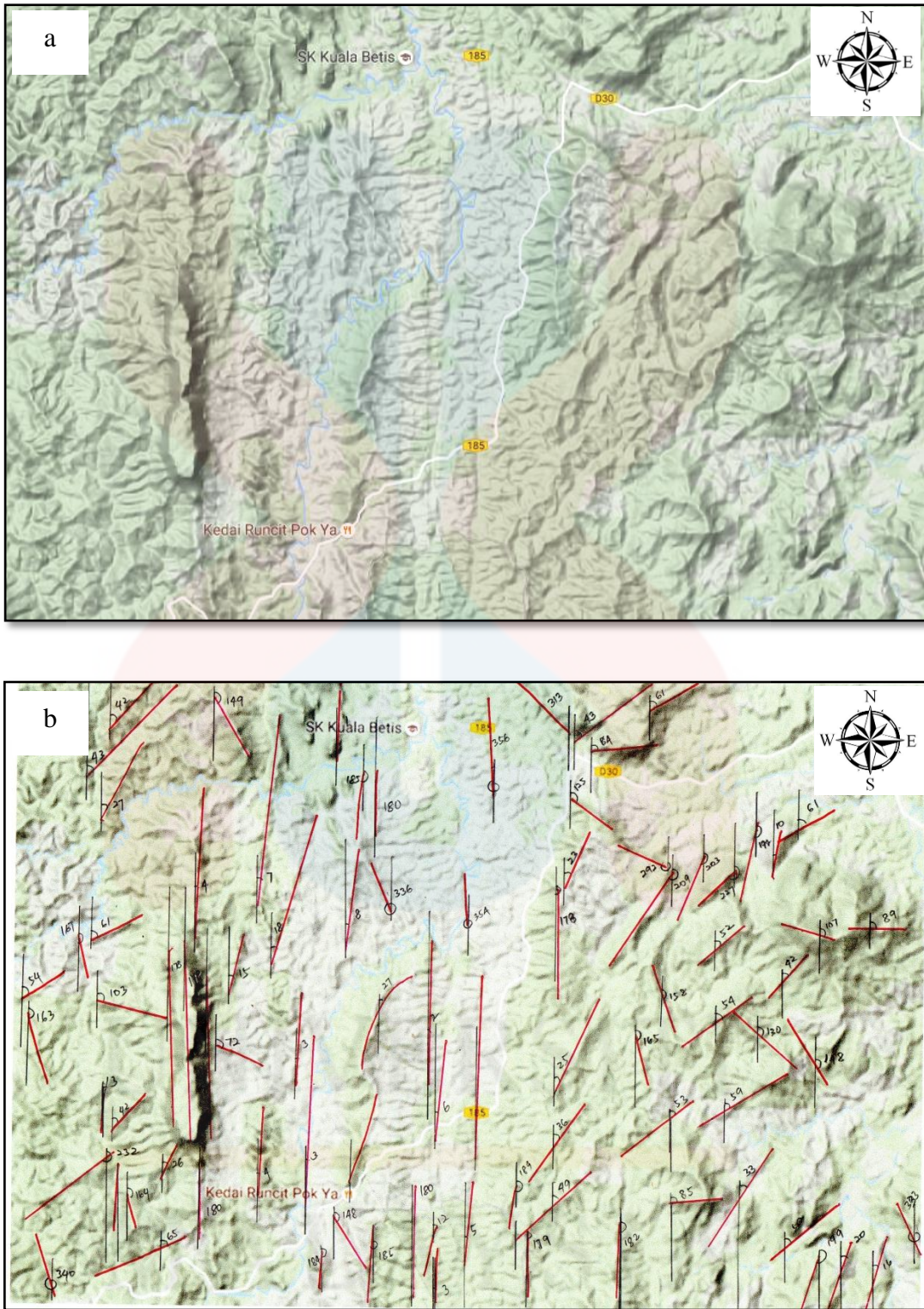
#### 4.5.1 Lineament

Lineament can be divided into two types, linear or curvilinear. It is the feature part that align in a straight or curving relationship that reflects the tectonic structure due to the structural deformation process. Lineament is controlled by structures such as joints, faults, folds, ridges and many more. During field observation, a straight rivers, valleys, are the geomorphological expressed in lineament.

Lineament can be recognized and interpreted from the topographic map, aerial photograph, and satellite imaginary from Google Earth. The lineament data is plotted in figure 4.27. During identifying the lineament, some mistakes or human error tend to happen, therefore, the lineament extraction data should be carefully interpreted.

The data for lineament is tabulated in table 4.5 and the result is presented in rose diagram in figure 4.28. The rose diagram will shows the direction of the main forces  $\sigma_1$ , shear direction and the tension direction.

By studying the lineament, the application can be used in mineral exploration, petroleum exploration as all those economic mineral and hydrocarbons tend to accumulate in the structured area.



**Figure 4.27** : a) The regional terrain map of the study area, (b) The lineament map of the study area. (source : Google Map Terrain, 2016)

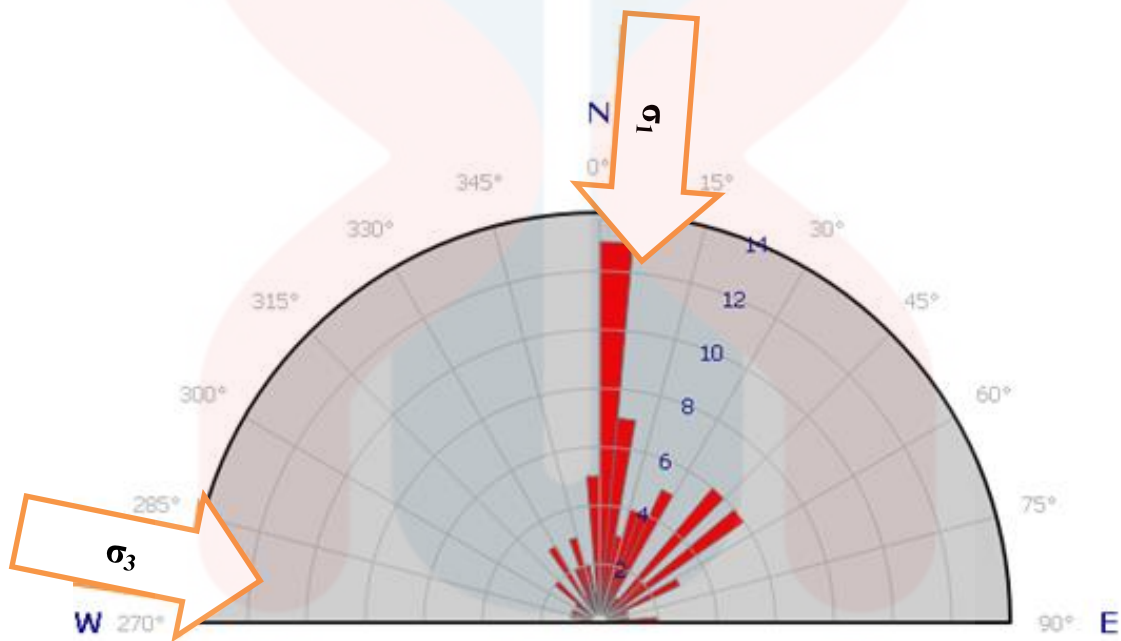
KELANTAN

**Table 4.5 :** The strike data for the lineament from the regional terrain map.

No.	Strike	No.	Strike	No.	Strike
1	042	29	001	57	209
2	043	30	185	58	203
3	027	31	180	59	227
4	167	32	336	60	192
5	061	33	027	61	010
6	054	34	148	62	061
7	103	35	184	63	107
8	163	36	185	64	089
9	003	37	180	65	042
10	042	38	003	66	052
11	232	39	012	67	158
12	340	40	006	68	165
13	164	41	002	69	053
14	065	42	354	70	085
15	026	43	356	71	059
16	178	44	313	72	050
17	178	45	043	73	148
18	004	46	084	74	130
19	149	47	125	75	054
20	007	48	061	76	042
21	018	49	023	77	020
22	015	50	178	78	004
23	072	51	025	79	333



24	180	52	036	80	016
25	003	53	189	81	199
26	184	54	049	83	020
27	005	55	179	83	033
28	008	56	292	84	182



**Figure 4.28 :** The rose diagram regional lineament showing the direction of main force ( $\sigma_1$ ) from the 005° North-East

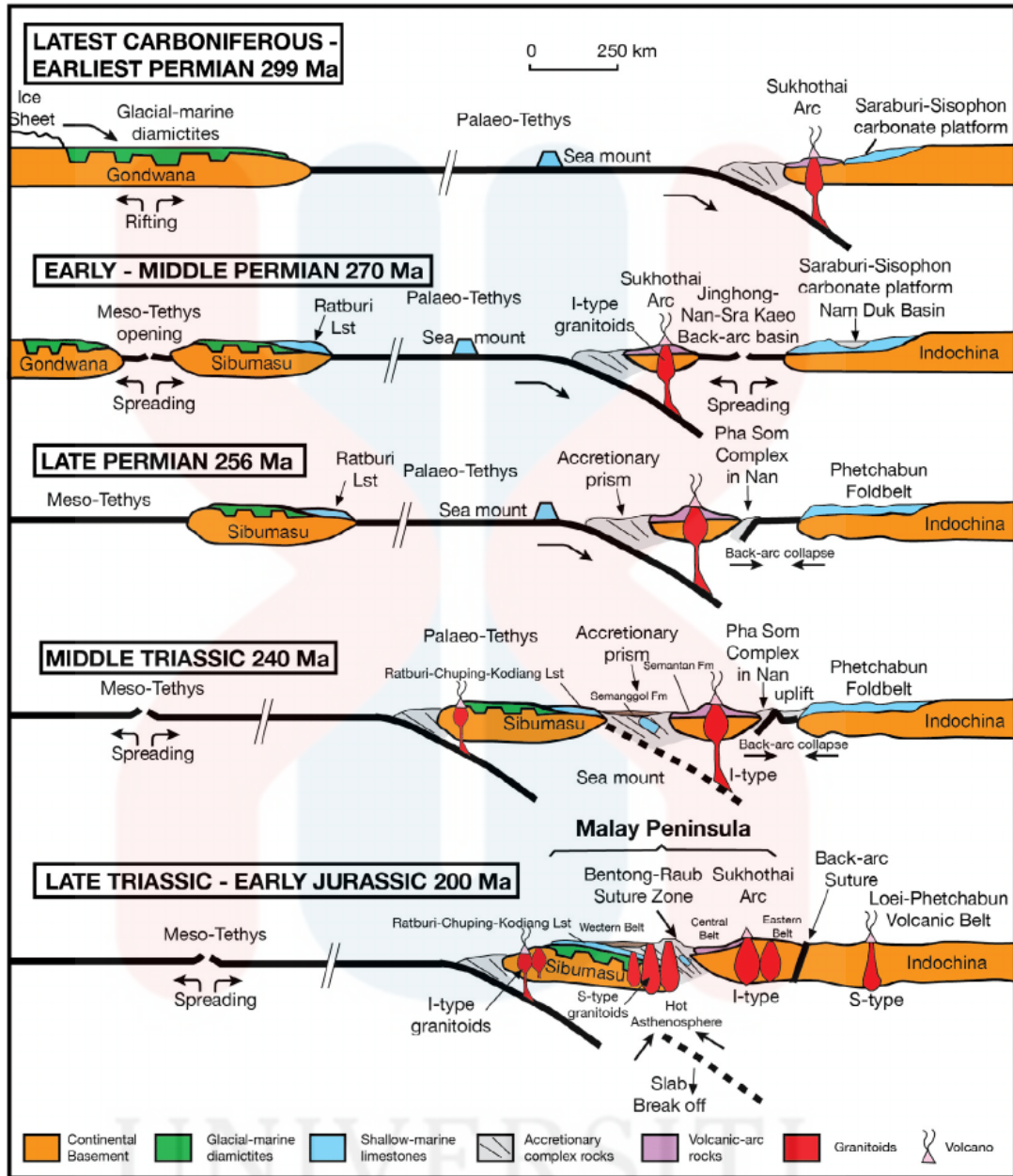
Based on the rose diagram in figure 4.28 regarding the regional analysis, the main force Sigma 1 ( $\sigma_1$ ) comes from the direction of 005° North-East while the Sigma 3 ( $\sigma_3$ ) comes from 275° North-West as Sigma 1 always perpendicular from Sigma 3.

The other details regarding structural geology of the study area such as folds, faults, joints, bedding analysis are presented in chapter 5, structural analysis.

#### 4.6 Historical Geology

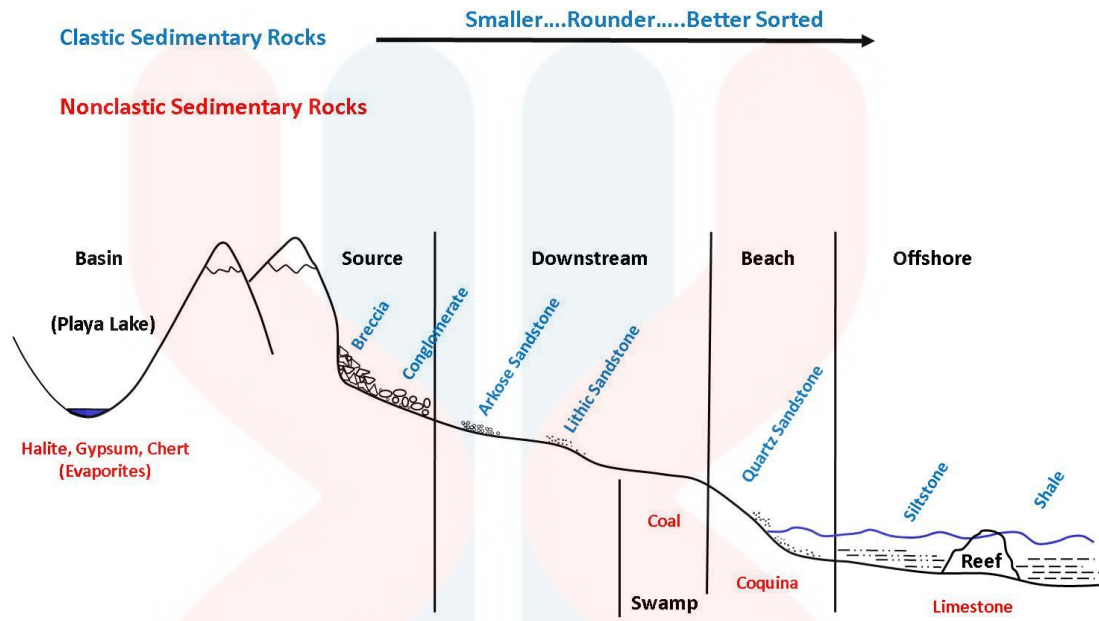
This study focuses on geological processes that form the lithology of the study area by reconstruct and understand the change to the landscape. In generally, the study area located at the Bentong-Raub suture zone within the collision zone between Sibumasu plate and Indochina plate during Upper Permian and was completed by Upper Triassic. In the past, Peninsular Malaysia and the regional South-East Asia countries such as Thailand and Vietnam were originally located deep down in the Paleo-Tethys Ocean. From the stratigraphic column, there are three formations that have been identified in the study area which are Semanggol Formation, Karak Formation and Gua Musang Formation. Semanggol Formation located at deep marine environment based on the chert lithology while Karak Formation and Gua Musang Formation located at shallow marine environment.

Basir (2013) had stated that the oceanic plate of Sibumasu terrane that represents Semanggol Formation had been subducted under the Indochina plate that represent Karak Formation and Gua Musang Formation during the collision. From the collision, it produces compressional reverse faulting in imbricated structures, lateral fault movements and large-scale extensional fault (Tija, 1996). Breccia lithology identified is the product of faulting that happened during Lower Triassic that formed Gunung Ayam in Lojing area. Figure 4.29 illustrate the time lapse of tectonic evolution regionally at study area. The depositional environment for the study area is illustrated in Figure 4.30 as the study area consist of breccia, conglomerate, limestone, sandstone, siltstone and shale.



**Figure 4.29** : Cartoon showing the tectonic evolution of Sundaland (Thailand–Malay Peninsula) and evolution of the Sukhothai Arc System during Late Carboniferous–Early Jurassic times. (Metcalf, I., 2013)

## Depositional Environments of Sedimentary Rocks



**Figure 4.30** : The depositional environments of sedimentary rocks is study area. (source: <http://geo.illinoisstate.edu>)

## CHAPTER 5

### STRUCTURAL ANALYSIS

#### 5.1 Introduction

This chapter discussed about all the structural analysis that located in the study area. Desk study is done before going to field work, by using the satellite imaginary and topographic map the locations of all possible structured area within study area have been determined and pinpointed. Then, the field work is done to gather the data, and to prove the area contain structured features. All the data regarding the structure analysis such as strike and dip of the beddings, joints, veins, faults, and folds had been collected, then the data is interpreted using Stereonet and rose diagram.

The Peninsular of Malaysia is formed due to the collision between the Indo-China plate and Sibumasu plate during Upper Permian give result to the formation of the Bentong-Raub suture zone. The extension of the Bentong-Raub Suture is from Tomo, at southern part of Thailand, going southward through Bentong and Raub until Melaka.

#### 5.2 Fold Analysis

Fold is a structural feature that formed when a planar surface, such as strata or beds are bent or in curved shape. Fold occurred due to the ductile deformation because it the feature is developed without breaking or fracturing the rocks and it is heterogeneous. From the geometry of folds, the orientation and degree of strain can be determined. It store the crucial information about

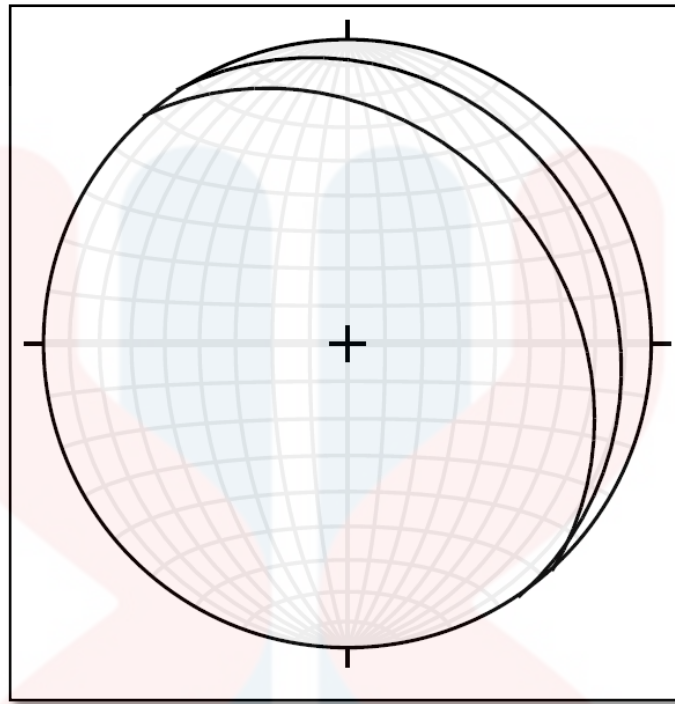
deformation history in the region. Folds can be in both small and large scales.

To analyse the folds within study area, the stereonet were plotted AS shown in fogure 5.2 and figure 5.3 to find the plunge of the fold, which are Sigma 1 ( $\sigma_1$ ), Sigma 2 ( $\sigma_2$ ), Sigma 3 ( $\sigma_3$ ). The Sigma ( $\sigma$ ) is representing the force that applied to the rock.

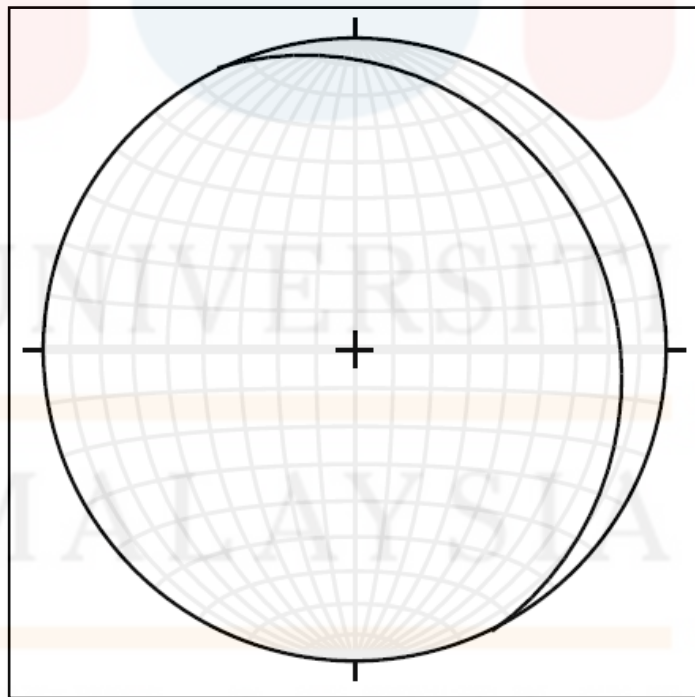


**Figure 5.1** : The open fold with only half limb at the sandstone interbedded with shale outcrop.

UNIVERSITI  
MALAYSIA  
KELANTAN



**Figure 5.2 :** The stereonet for open fold with only half limb at the sandstone interbedded with shale outcrop.



**Figure 5.3 :** The stereonet for bed at the sandstone interbedded with shale outcrop.

### 5.3 Fault Analysis

Fault is a fracture along the Earth's crust. Fault is defined when two adjacent blocks of rock moved past each other due to induced stresses. A fault plane is the plane that represent the fracture surface of the faults. The fault can extend only a few centimetres to several hundreds of kilometres along the fault plane, as example, San Andrea's Fault. Fault occurred when the maximum differential stress exceeds the shear strength of a rock formation. The type of stress that exist during fault is confining stress where all force of stress is equal.

The fault can be recognized in the field by three type of evidence which are :

1. Geological evidences
2. Fault Plane evidences
3. Physiographic evidences

The examples for geological evidences are :

- a. Offset of rock unit, where there is displacement of rock beds, dyke or vein, usually occurs on opposite site of faults
- b. Repetition and omission of strata, this occurs during in a traverse line, the outcrop of a bed repeated in cyclic order or disappear
- c. Stratigraphic sequence, older strata occur above younger strata.

The fault plane evidences which are :

1. The presence of feather joints
2. Slickensides and slicken line

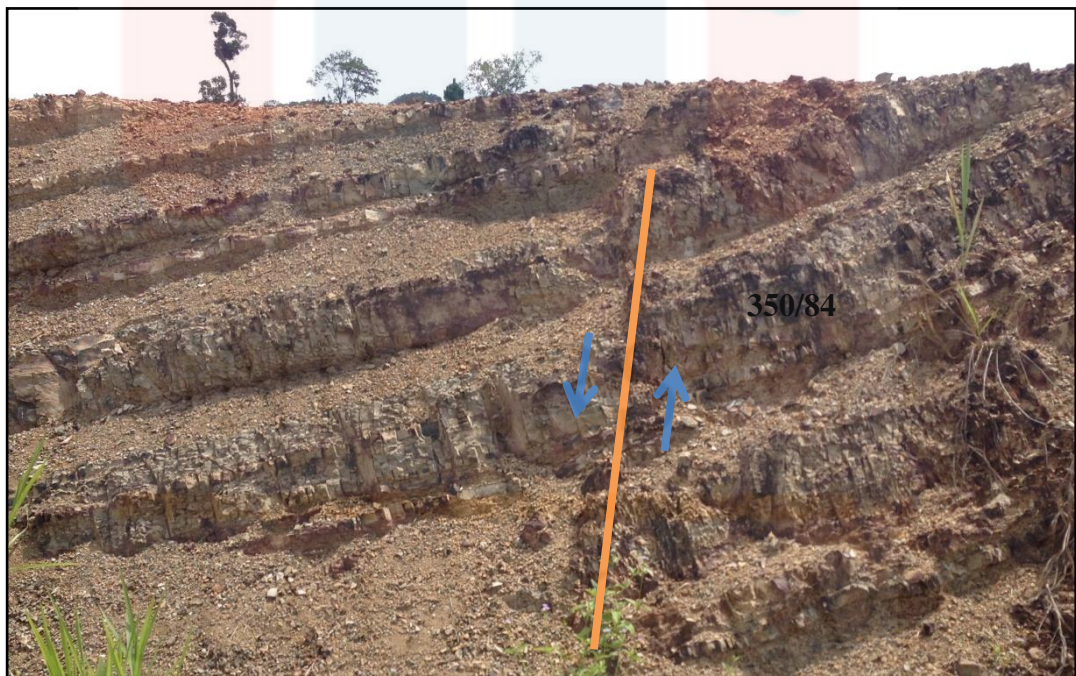


3. Drag fold
4. Fault breccia, gouge structure
5. Silicification and mineralization.

For Physiographic evidence, they are :

1. Faults scarp
2. Fault line scarp
3. Fault control of streams

In the study area, the fault can be observed at the outcrop sandstone interbedded with shale at the cutting slope besides the Gua Musang-Cameron Highland highway. The fault was shown in figure 5.4.

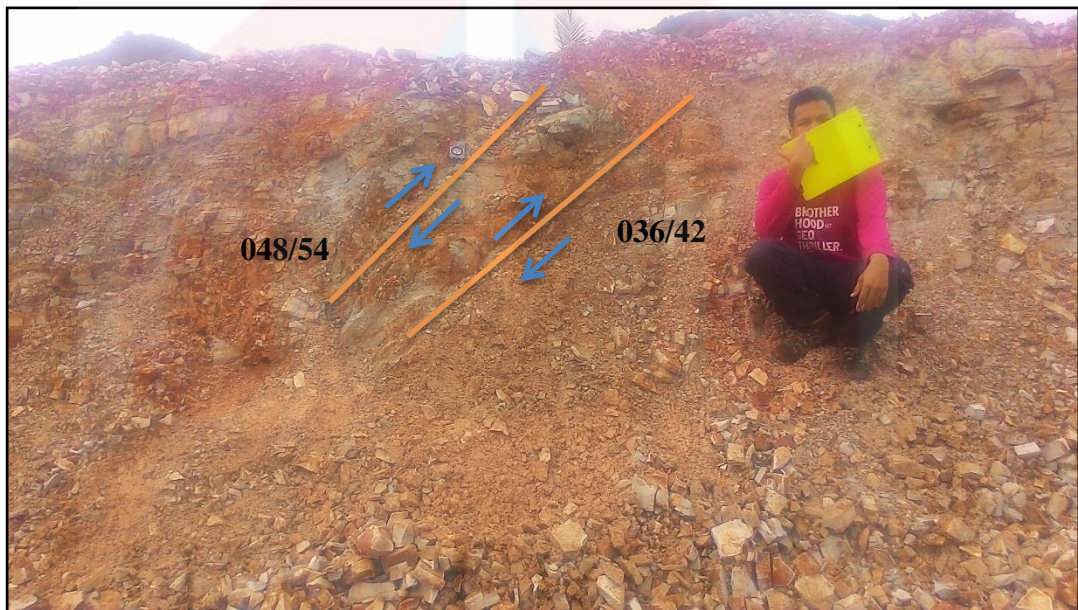


**Figure 5.4** : The appearance of normal fault at the roadside of Gua Musang-Cameron Highland highway, hammer as the scale.

KELANTAN

The normal fault that shown in figure 5.4 had the measurement of dipping with  $84^\circ$  and strike at  $350^\circ$ . From the observation, the hanging wall moving downward while the foot wall moving upward. The stereonet was plotted to determine the direction of stress that applied on the beds.

The next fault location can be observed at the tuffaceous outcrop in the middle of palm plantation estate. There is two faults that can be observed within one outcrop. The fault lines is filled with iron oxide minerals. The strike and dipping for fault (i) and fault (ii) are  $048^\circ/54^\circ$  and  $036^\circ/42^\circ$ .



**Figure 5.5 :** The reverse faults at tuffaceous outcrop

MALAYSIA

KELANTAN

#### 5.4 Joints Analysis

Joint can be divided into two, shear joint and extensional joint. Joint is one kind of fracture that dividing the rock into two sections. The shear joint is the joint that has no displacement or only a small displacement. The extensional joints is the joint that had some displacement and had minerals that filled the gap between the rock that fractured.

In order to do the joint analysis, a locations had been chosen within the study area. The accuracy of the data is depends on how much the reading of strike and dip of the joint is taken during the fieldwork, as much data will gave much better and accurate result. With the joints analysis, the direction of forces within the study area can be determined. The data that had been gathered is presented in Table 5.1 and plotted into the rose diagram.



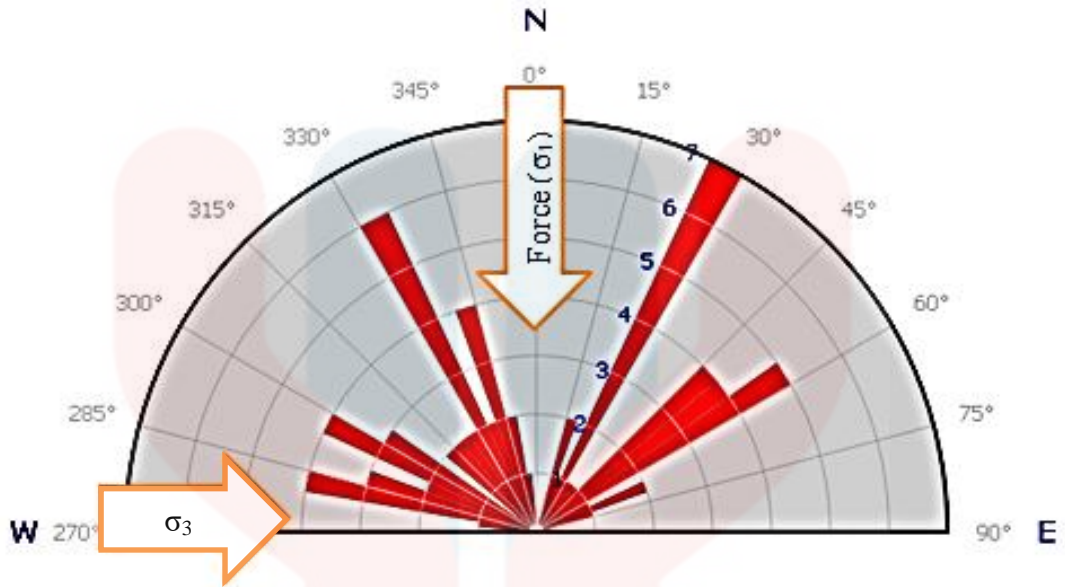
**Figure 5.6 :** The shear and extensional joint on sandstone outcrop.

**Table 5.1 :** The joint orientation data.

<b>No.</b>	<b>Orientation</b>	<b>No.</b>	<b>Orientation</b>
1	151	36	134
2	207	37	100
3	141	38	208
4	206	39	235
5	228	40	210
6	245	41	104
7	209	42	107
8	100	43	119
9	221	44	118
10	147	45	299
11	153	46	149
12	158	47	047
13	232	48	133
14	237	49	106
15	167	50	114
16	239	51	101
17	169	52	114
18	174	53	108
19	150	54	237
20	234	55	152
21	204	56	206
22	195	57	140
23	135	58	227

24	233	59	243
25	137	60	209
26	206	61	160
27	161	62	219
28	158	63	150
29	225	64	152
30	246	65	160
31	122	66	235
32	071	67	051
33	121	68	118
34	161	69	097
35	124	70	199

Based on the rose diagram in Figure 5.7, the main force ( $\sigma_1$ ) come from the Northern part of the study area, why the tensional force ( $\sigma_3$ ) come from the Western part of the study area as the tensional force always perpendicular with main force.



**Figure 5.7 :** The rose diagram showing the direction of main force which is from North.

### 5.5 Lineament Analysis in Study Area

Lineament can be divided into two types, linear or curvilinear. It is the feature part that align in a straight or curving relationship that reflects the tectonic structure due to the structural deformation process. The data for the lineament within the study area is collected by using topographic map as shown in map 5.1 by observing the contours pattern and the stream direction.

The data for lineament is tabulated in table 5.2 and the result is presented in rose diagram in figure 5.6. The rose diagram will shows the direction of the main forces  $\sigma_1$ , shear direction and the tension direction.

**Table 5.2 :** Data strike for lineament in study area.

No.	Strike	No.	Strike	No.	Strike
1	093	24	123	47	061
2	090	25	128	48	073
3	071	26	129	49	122
4	107	27	090	50	096
5	090	28	069	51	113
6	088	29	114	52	253
7	090	30	060	53	134
8	088	31	100	54	096
9	090	32	044	55	146
10	078	33	063	56	040
11	104	34	140	57	100
12	105	35	058	58	065

13	095	36	041	59	044
14	090	37	320	60	099
15	132	38	192	61	090
16	148	39	038	62	126
17	123	40	180	63	198
18	105	41	310	64	180
19	090	42	350	65	044
20	092	43	108	66	085
21	090	44	113	67	071
22	082	45	082	68	121
23	241	46	072	69	148

From the rose diagram in figure 5.8 its can be conclude that, the main force comes from North-West while the tensional force acting on the 20° North-East direction.



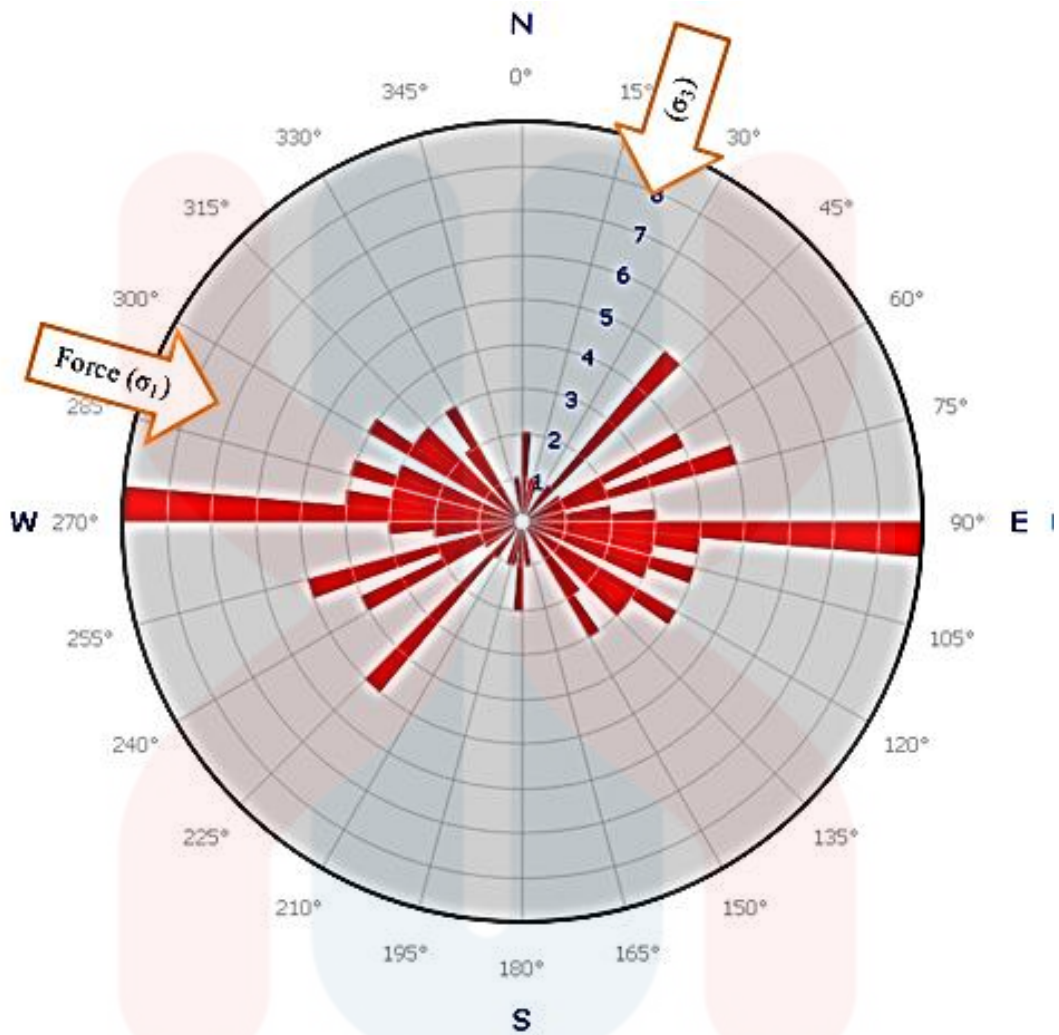
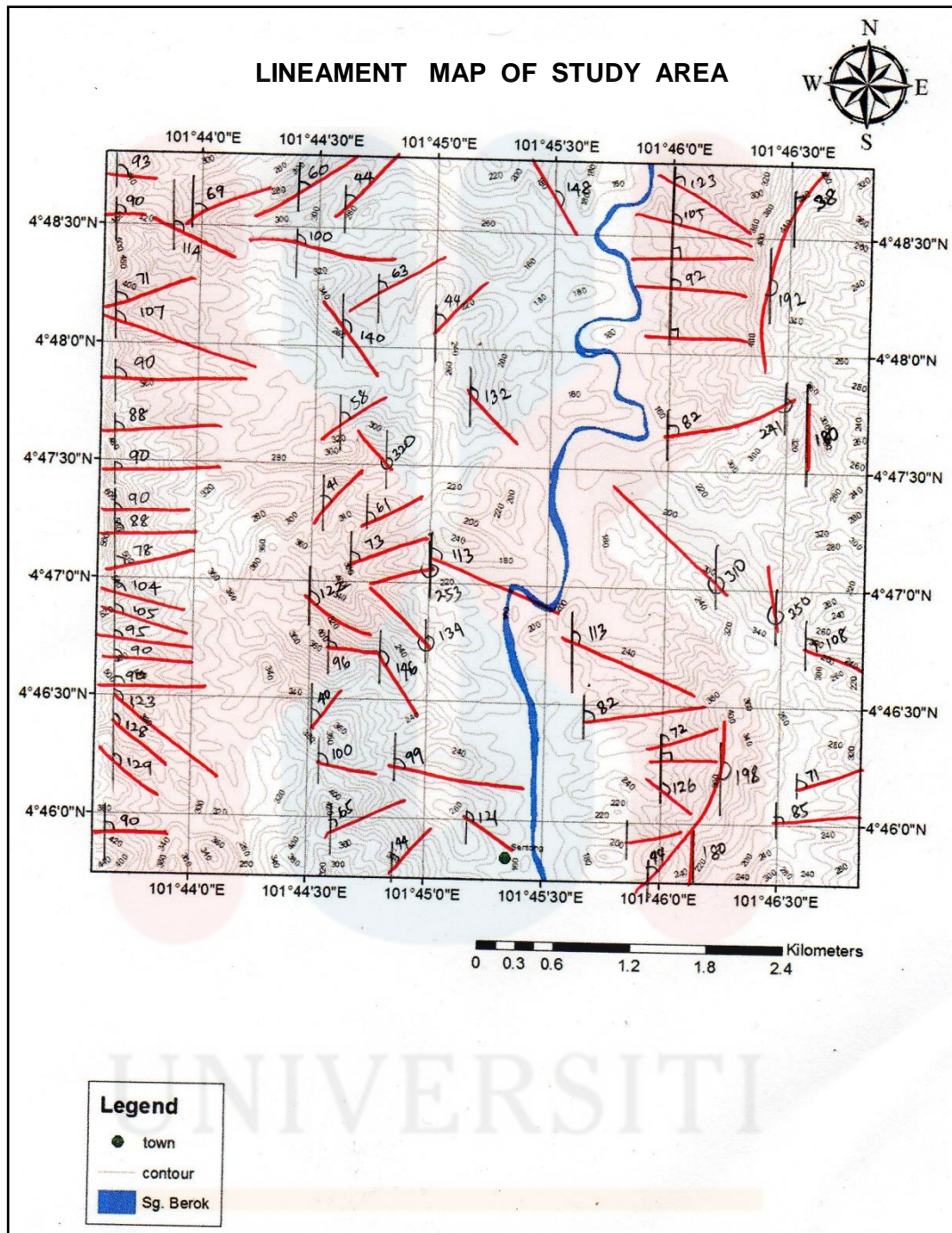


Figure 5.8: The rose diagram for lineament within the study area.

UNIVERSITI  
MALAYSIA  
KELANTAN



Map 5.1 : The lineament map of the study area.

## 5.6 Bedding Analysis

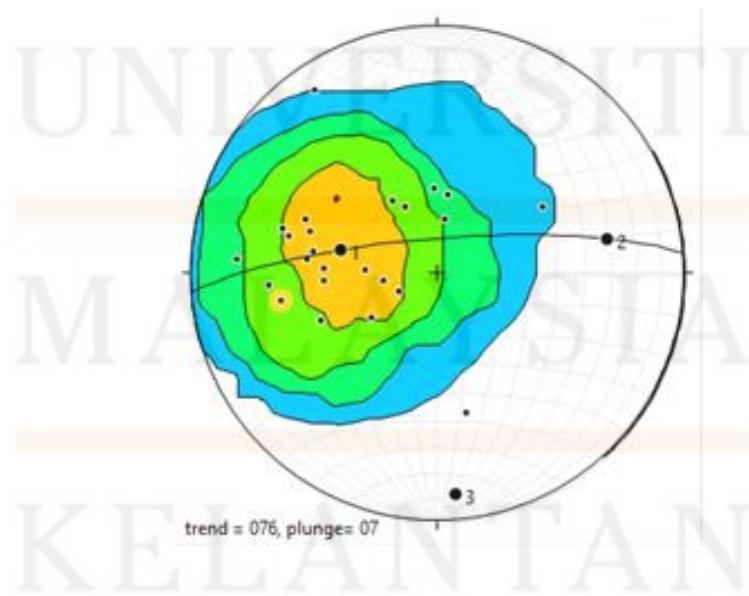
Bed is a rock layer that contain uniform lithology with same texture. Beds form due to deposition of layers of sediment that overlain each other forming the sequence of beds. Bedding is one of the features for sedimentary rock.

Bedding analysis required the measurement for strike and dip for all sedimentary outcrop that found within the study area. The data for Bedding analysis is tabulated in table 5.3. By analysing the bedding, the direction of the forces that take place within the study area can be determined. The force direction pattern of bedding is plotted and interpreted using stereonet diagram as shown in figure 5.4.

**Table 5.3** : The strike and dip measurement for bedding outcrop.

No.	Strike	Dip	Dip Quad
1	364	70	E
2	016	55	E
3	018	45	E
4	022	48	E
5	006	44	E
6	014	52	E
7	326	26	E
8	352	18	E
9	334	14	E
10	098	18	S

11	098	26	S
12	058	28	S
13	064	24	S
14	148	42	W
15	088	28	S
16	002	24	E
17	350	54	E
18	356	38	E
19	338	42	E
20	358	48	E
21	356	58	E
22	056	78	S
23	010	42	E
24	002	38	E



**Figure 5.9** : The Stereonet plot for bedding analysis.

## CHAPTER 6

### CONCLUSION AND RECOMMENDATION

#### 6.1 Introduction

This chapter elaborate about the conclusion and recommendation for this research. The conclusion will focus on the general geology and the structural analysis of the study area. The recommendation explain about the future research topic and the overall finding regarding the study area.

#### 6.2 Conclusion

In general, the study area consist of carbonate rock, siliciclastic rock and meta sedimentary rock. For siliciclastic rock, its consist of conglomerate, sandstone, shale, siltstone, mudstone and breccia. The oldest rock in the study area is metamorphic rock aged Silurian to Devonian. The carbonate rock and siliciclastic rock are under Gua Musang formation which age from Late Carboniferous to Middle Triassic.

From the structural analysis of the study area it can be conclude that major forces that take place in study area region, comes from the Northern part of the region.

The update of geological map regarding the study area were construct in scale 1:25 000.

### 6.3 Recommendation

Gunung Ayam area consist of very interesting geological features such as structural geology, paleontology, sedimentology, hydrogeology and many more, it is recommended that, the further study should be done in the future. The Gunung Ayam area as well as Lojing area should become the Geoheritage site because of a lot of stories regarding geologic features of that area is still unrevealed. It is highly recommended that, the research activity should be done during hot days and avoid doing the research during Northeast monsoon as the area is quite dangerous during raining seasons.

## REFERENCES

- Abdul Rahim Samsudin, Kamal Roslan Mohamad, Ibrahim Abdullah & Abdul Ghani Rafek (1994). Kajian geofizik di Kuala Betis, Kelantan. *Geological Society of Malaysia Bulletin*, 35, 169-174.
- Aw, P.C (1974). Geology of Sungai Nenggiri – Sungai betis area, sheet 44, *Geological Survey Malaysia Annual Report 1974*, pg. 115-119.
- Basir Jasin, Atilia Bashardin & Zaiton Harun (2013). Middle Permian Radiolarians from the siliceous mudstone block near Pos Blau, Ulu Kelantan and their significance, *Geological Society of Malaysia*, 59, 33-38
- Davis, G. H. (1996). Structural Geology of Rocks And Region. United States of America: John Wiley & Sons, Inc.
- Department of Geography Geology (2014). Depositional environments of Sedimentary rock. Retrieved October 29, 2016, from Illinois State University ©2014 Illinois State University. <http://geo.illinoisstate.edu/weshiel/Videos/Sed%20Env.mp4>.
- Department of Mineral and Geoscience Malaysia (2000). Land use of Kelantan State.
- Department of Mineral and Geosciences Malaysia (2003). Quarry Resource Planning for the state of Kelantan
- Department of Statistic Malaysia (2010). Population development in Kelantan. [www.citypopulation.de/php/malaysia-admin/php?adminid=03](http://www.citypopulation.de/php/malaysia-admin/php?adminid=03)
- Department of Minerals and Geoscience Malaysia (2003) Quarry Resource Planning for the State of Kelantan. Osborne & Chappel Sdn. Bhd.
- Dzulkafli. M. A, Basir Jasin & Leman, M. S, (2010). Penemuan radiolarian berusia Perm dari kawasan sekitar Pos Belau, ulu Kelantan. *National Geological Conference 2010*. Abstract of paper pg 116.
- Google Earth*. (2016, April). Retrieved April 18, 2016, from Google Map: [imaginary©2016 Cnes/Spot Image, CNES/Astrium, Map data©2016Google https://www.google.com/maps/place](https://www.google.com/maps/place)
- Google Earth*. (2016, April). Retrieved April 18, 2016, from Google Map: [Map data ©2016 Google. https://www.google.com.my/maps](https://www.google.com.my/maps)
- Hepburn, H. R., & Radloff, S. E. (2011). Biogeography. In *Honeybees of Asia* (pp. 51-67). Springer Berlin Heidelberg.
- Ibrahim Abdullah & Jatmika Setiawan, (2003). The Kinematic of deformation of the Kenerong leucogranite and its enclaves at Renyok waterfall, Jeli Kelantan. *Geological Society of Malaysia Bulletin*, 46, 307-312.

- Ichikawa, K. & Yin, E. H., (1996). Discovery of Early Triassic Bivalves from Kelantan, Malaya. *Journal of Geoscience, Osaka City University*, pg 123 - 130.
- Jatmika Setiawan & Ibrahim Abdullah., (2010). Geologi Struktur pada Formasi Gua Musang di Negeri Kelantan. *National Geoscience Conference 2010*. Abstract of paper pg. 44.
- John W. Barnes, Richard J. Lisle, (2004). Basic Geological Mapping, 4<sup>th</sup> ed, England, John Wiley & Sons, Ltd.
- Kelantan Meteorological Department (2015). Total rain distribution in Gua Musang from 2011 until 2015.
- Majlis Daerah Gua Musang (2015). Data Taburan Penduduk di jajahan Gua Musang mengikut daerah.
- Metcalf, I. (2013). Tectonic evolution of the Malay Peninsula. *Journal of Asian Earth Sciences*, 76, 195-213.
- Mohd Shafeea Leman, (1994). Permian Ammonoids from Kuala Betis area, Kelantan and their paleogeographic significance. *Geological Society Conference 1995*. pp 153-158.
- Nazaruddin, D. A., & Othman, A. R. (2014). Geoheritage Conservation of Paleontological Sites in Aring Area, Gua Musang District, Kelantan, Malaysia. *International Journal on Advanced Science, Engineering and Information Technology*, 4(1), 14-19.
- Nazaruddin, D. A., Fadilah, N. S. M., & Zulkarnain, Z. (2014). Geological Review of the Rafflesia Trail, Near Kampung Jedip, Lojing Highlands: Inputs for a Nature-Based Tourism Site in Kelantan, Malaysia. *J. Trop. Resour. Sustain. Sci*, 3, 86-97.
- Nazaruddin, D. A., Fadilah, N. S. M., & Zulkarnain, Z. (2015). Geological Review of the Rafflesia Trail, Near Kampung Jedip, Lojing Highlands: *Inputs for a Nature-Based Tourism Site in Kelantan, Malaysia*. *J. Trop. Resour. Sustain. Sci*, 3, 86-97.
- Nuraiteng Tee Abdullah (2009). Geology of Peninsular Malaysia (Vol : Mesozoic Stratigraphy). Kuala Lumpur, Malaysia : *University of Malaya and Geological Society of Malaysia*.
- Paul, M.S. (2006). Field Methods for Characterizing Weak Rock for Engineering, *The Geological Society of America*, XII, 1-11
- Shuib. M. K, (1994c). Structures within the Bentong Suture Zone along the Cameron Highland-Gua Musang road (abstract). *Geological Society of Malaysia Warta Geologi*, 20, 232-233.
- Thornbury, W.D., (1969). Principles of Geomorphology (2nd Edition), Wiley and Sons, New York, 119-128



- Tjia, H.D., (1999). Geological Setting of Peninsular Malaysia. In PETRONAS. *The Petroleum Geology and Resource of Malaysia*, Kuala Lumpur, pp 139-169.
- Tjia, H. D., & Zaiton H. (1985). Regional structures of peninsular Malaysia. *Sains Malaysiana*, 14(1), 95-107.
- Tjia, H.D. and Almashoor, S.S., (1993). The Bentong suture zone in Ulu Kelantan , Peninsular Malaysia, *IGCP 321 Gondwana dispersion and Asian Accretion, 3<sup>rd</sup>. International Symposium and Field excursion*. Abstracts of papers p 70-71.
- Tjia, H.D., (1986). Geological transport direction in Peninsular Malaysia, *Geological Society of Malaysia Bulletin* 20, 149-177.
- Tjia, H.D., (1987). Olistostrome in Bentong area, Pahang, *Warta Geologi* 13, 105-111.
- Tjia, H.D., ( 1989a). The Bentong Suture. In : *Situmorang, B. (Ed.), Proceedings of the Regional Conference on Mineral and Hydrocarbon Resources of SE Asia*, pp. 73-85.
- Tjia, H.D., (1989b). Tectonic history of the Bentong - Bengkalis Suture. *Geologi Indonesia* 12, 89-111.
- Tjia, H. D. & Syed Sheikh Almashoor, (1996). The Bentong suture in southwest Kelantan, Peninsular Malaysia, *Buletin of the Geological Society of Malaysia* 39, 195-211.
- Van Der Pluijm, Ben A., (2004). *Earth Structure – Introduction to Structural Geology and Tectonic*, 2<sup>nd</sup> Edition, United State of America, W. W. Norton & Company, Inc.
- World weather online. (n.d.). Retrieved 20 April, (2016), from <http://www.worldweatheronline.com/gua-musang-weather-averages/kelantan/my.aspx>
- Yin ,E.H, (1965). Provisional Draft Report on the Geology and Mineral Resources of Gua Musang Area, sheet 45, South Kelantan, pg 1-27.