



Universiti Malaysia
KELANTAN

DETERMINATION OF OIL AND GREASE IN WATER
DISCHARGE FROM UMK JELI CAFETERIAS

by

NURUL AIDA BINTI SIMAN

A report submitted in fulfilment of the requirements for the degree of
Bachelor of Applied Science (Sustainable)

FACULTY OF EARTH SCIENCE

UNIVERSITY MALAYSIA KELANTAN

2017

DECLARATION

I declare that this thesis entitled “Determination of Oil and Grease in Water Discharge from UMK Jeli Cafeterias” is the result of my own research except as cited in the references. The thesis has not been accepted for any degree and is not concurrently submitted in candidature of any other degree.

Signature : _____

Name : _____

Date : _____

UNIVERSITI
MALAYSIA
KELANTAN

ACKNOWLEDGEMENT

First of all, my praise is to Allah, the Almighty, the most Gracious and the most Compassionate which we depend for guidance. Then my appreciation goes to my supervisor Miss Nor Sayzwani Binti Sukri who always giving me supports, guidance, extra information, also careful reading and constructive comments that was valuable for me. With her timely and efficient contribution helped me shape this into its final form.

My deepest appreciation to the Faculty of Earth Science, University Malaysia Kelantan for providing all the facilities and equipments needed in my study. Special thanks to all lab assistants who assist me and providing the materials that need to be used in my study.

My sincere thanks goes to my friends who helped me a lot during my sampling and laboratory sessions. And also, thanks, tribute and appreciation to all my examiners who have contributed to the successful completion of this thesis.

I would like to thank my family for their support. I am deeply and forever indebted to my parents, Siman bin Sirin and Nafishah bt Isa, for their love, support and encouragement throughout my entire life.

UNIVERSITI
MALAYSIA
KELANTAN

ABSTRACT

Oil and Grease (OG) is a measure of a variety of substance including motor oil, cooking oil and fuels. The increasing number of education institution place in Malaysia contributes to the development of food industries such as cafeteria and food stall that produces huge amount of waste that may causing a negative effect towards health and environment if it does not being treated. It is because the waste contain high level of total suspended solid such as oil and grease. The sources of oily water discharged in UMK Jeli come from the 2 cafeterias in UMK Jeli itself. This study was conducted to analyze the concentration of oil and grease in UMK Jeli cafeterias water discharge and nearby river and to compare oil and grease concentration in water discharge from UMK Jeli cafeterias and nearby river with Environmental Quality Act (EQA) standard guideline. This study was conducted by using Hexane Extractable Gravimetric Method. The data for monthly concentration of oil and grease taken from May 2016 to October 2016, in water discharged from all the sampling point which is Medan Selera, IBS Cafe, Lanas River and Gemang River are below 10 mg/l, which is the EQA standard for oil and grease in water effluent. All of the data obtained contained the low concentration of oil and grease in it due to the usage of filter paper during the drainage process of the solvent layer. The filter paper trapped some of the oil contents in the solvent layer which were important in determination of oil and grease. The data shows that the concentration of oil and grease in Medan Selera water discharged are the highest among all the sampling points and affecting the concentration of oil and grease in nearby river which is Lanas River.

UNIVERSITI
MALAYSIA
KELANTAN

ABSTRAK

Minyak dan gris (OG) adalah ukuran pelbagai bahan termasuk minyak motor, bahan api dan minyak masak. Peningkatan bilangan tempat institusi pendidikan di Malaysia menyumbang kepada pembangunan industri makanan seperti kafeteria dan gerai makan dimana menghasilkan sisa yang boleh menyebabkan kesan negatif terhadap kesihatan dan alam sekitar jika ia tidak dirawat. Ini kerana sisa-sisa itu mengandungi sejumlah besar pepejal terampai seperti minyak dan gris. Sumber-sumber air berminyak dilepaskan di UMK Jeli datang dari kafeteria 2 di UMK Jeli itu sendiri. Kajian ini dijalankan untuk menganalisis kepekatan minyak dan gris dari air buangan dan sungai berhampiran cafeteria UMK Jeli dan untuk membandingkan kepekatan minyak dan gris di dalam air sisa yang dilepaskan dari kafeteria UMK Jeli dan sungai berhampiran dengan garis panduan piawaian Akta Kualiti Alam Sekitar (EQA). Kajian ini dijalankan dengan menggunakan kaedah Gravimetric Extractable heksana. Data bulanan untuk kepekatan minyak dan gris di dalam air yang dilepaskan dari Medan Selera, IBS kafe, Sungai Lanas dan Sungai Gemang menunjukkan kepekatan minyak dan gris adalah dibawah kepekatan 10mg/l, iaitu had garis panduan EQA. Semua data yang diperolehi menunjukkan kepekatan minyak dan gris yang rendah kerana penggunaan kertas turas semasa proses penapisan lapisan pelarut. Kertas turas yang digunakan memerangkap minyak dan gris yang terkandung di dalam lapisan pelarut yang harus diambil kira dalam menentukan kepekatan kandungan minyak dan gris. Analisis data mendapati bahawa kepekatan minyak dan gris terkandung di dalam air yang dilepaskan dari Medan Selera adalah yang tertinggi berbanding semua titik persampelan dan mempengaruhi kepekatan minyak dan gris dalam sungai yang berdekatan iaitu Sungai Lanas.

TABLE OF CONTENTS

	PAGE
TITLE PAGE	i
DECLARATION	ii
ACKNOWLEDGEMENT	iii
ABSTRACT	iv
ABSTRAK	v
TABLE OF CONTENTS	vi
LIST OF TABLES	viii
LIST OF FIGURES	ix
LIST OF ABBREVIATIONS	xi
CHAPTER 1 INTRODUCTION	
1.1 Background of study	1
1.2 Problem statement	2
1.3 Objectives	3
1.4 Significance of study	4
CHAPTER 2 LITERATURE REVIEW	
2.1 Oil and Grease	5
2.2 Waste water effluent discharge standards	7
2.3 Oily water discharge	8
2.4 Water Quality Standard	8
2.4.1 Physico-Chemical Parameters	9
CHAPTER 3 MATERIALS AND METHODS	
3.1 Materials and Reagents	15
3.2 Sampling Location	15
3.3 Sample collection and storage	18
3.4 Preparation of Analysis Glassware	18
3.5 Distillation apparatus assembly	18
3.6 Test procedure	19
3.6.1 Separation of solvent and water layer	19

3.6.2	Draining of solvent and water layer	20
3.6.3	Distillation of n-hexane	21
3.7	Calculation	22
3.8	Water Quality Analysis	23
3.8.1	In-situ test	23
3.8.2	Ex-situ test	23
3.8.2.1	BOD test	23
CHAPTER 4 RESULTS AND DISCUSSIONS		
4.1	River Parameters	25
4.1.1	Temperature	27
4.1.2	Conductivity	28
4.1.3	Dissolve Oxygen (DO)	29
4.1.4	Total Dissolve Solid (TDS)	30
4.1.5	Turbidity	31
4.1.6	Biological Oxygen Demand (BOD)	32
4.2	Oil and Grease	33
4.3	Comparison with EQA Standard Guideline	35
CHAPTER 5 CONCLUSION & RECOMMENDATION		
5.1	Conclusion	40
5.2	Recommendation for Future Research	41
REFERENCES		43
APPENDICES A		46

LIST OF TABLES

Table		PAGE
2.1	Environmental Quality Act (EQA) standard guideline for water effluent	8
2.2	National Water Quality Standards for Malaysia	9
4.1	Physicochemical parameter in Lanas River and Gemang River.	26
4.2	Total oil and grease collected	33
4.3	Comparison of oil and grease with EQA Standards	36

LIST OF FIGURES

FIGURE		PAGE
2.1	The pH scale	13
3.1	Map of sampling area	17
3.2	Distillation apparatus assembly	19
3.3	Analytical flow for determination of oil and grease	22
4.1	The temperature of Lanas River and Gemang River from May to October 2016.	27
4.2	The conductivity of Lanas River and Gemang River from May to October 2016.	28
4.3	The dissolved oxygen of Lanas River and Gemang River from May to October 2016.	29
4.4	The TDS of Lanas River and Gemang River from May to October 2016.	30
4.5	The turbidity of Lanas River and Gemang River from May to October 2016.	31
4.6	The BOD of Lanas River and Gemang River from May to October 2016.	32
4.7	Graph of month against total oil collected	33

4.8	Graph of EQA Standard comparison with Medan Selera.	37
4.9	Graph of EQA Standard comparison with IBS Cafe	38
4.10	Graph of EQA Standard comparison with Lanas River	38
4.11	Graph of EQA Standard comparison with Gemang River	39

LIST OF ABBREVIATIONS

ACS	American Chemical Society
BOD	Biological Oxygen Demand
BOD ₅	Biological Oxygen Demand (5 days)
DO	Dissolve Oxygen
EPA	Environmental Protection Agency
EQA	Environmental Quality Act
HEM	Hexane Extractable Material
IR	Infrared
OG	Oil and Grease
pH	Potential of Hydrogen
POME	Palm Oil Mill Effluent
TDS	Total Dissolve Solid
WWTP	Waste Water Treatment Plant
H ₂ O	Water
O ₂	Oxygen

UNIVERSITI
MALAYSIA
KELANTAN

CHAPTER 1

INTRODUCTION

1.1 Background of Study

Oil and Grease (OG) considered as vital parameter to determine the water quality and safety. Water effluent from food industrial including restaurants, school canteen, food processing factories and institutional cafeteria may contains high amount of oil and grease due to their consumption of nearly gallons of oil in their operation.

Meanwhile, water is an essential element in human life as they require water in every aspect of their life whether as drinking source, hygiene care and other needed. The clean water can sustain human and other biotic life in terms of human health, agricultures and other commercial purpose.

Unfortunately, the unmanaged oily water discharged can contribute to the water pollution. In the Niger-Delta, water effluents are typically pumped through pipelines to streams or the ocean (Isehunwa & Onovae, 2011). In some land areas, the water could be held in lakes before discharge into the environment while in offshore areas, it is released into the ocean through opened funnels under the surface of the water (Isehunwa & Onovae, 2011). The oily water discharge contain chemicals, heavy metals, dissolved solids, organic compounds, oil, grease, suspended solids, bacteria, suspended organic compounds and radioactive materials whether naturally occur or anthropogenic causes (Stenstrom *et al.*, 1986).

In general, the characteristics of produced water vary could with location and even with time within a single well (Isehunwa & Onovae, 2011). Oil and grease analyses attempt to quantify compound which have a greater solubility in an organic solvent than in water (Stenstrom *et al.*, 1986).

There are many methods that can be conducted to determine oil & grease and Total Petroleum Hydrocarbon in water such as trichlorotrifluoroethane (CFC-113, FREON 113) extraction and IR, EPA Method 1664A, EPA SW 9071B, EPA method 418.1, EPA method 8015B. In this study, EPA method 1664A also known as Hexane Extractable Gravimetric Method was used to determine the oil and grease because this method is more applicable to absorb oil and grease other than nonpolar material such as petroleum (Alade *et al.*, 2011).

1.2 Problem Statement

The contamination of oil and grease in water may bring bad effects. This is because oil and grease contains huge number of compounds such as fatty acid material of biogenic origin, or petroleum hydrocarbon constituent where all of these compounds can cause environmental degradation such as contamination of stream and river.

It can also become a major factor towards public health risks when discharged in environment including water, soil and underground water. Oily wastewater contains toxic substances such as phenols, petroleum hydrocarbons, polycyclic aromatic hydrocarbons, which are inhibitory to plant and animal growth, equally, mutagenic and carcinogenic to human being (Alade *et al.*, 2011).

The water discharged from both UMK Jeli cafeterias was flowing straight into the river nearby. It cause negative impact to the fresh water ecosystem especially aquatic life and as well as the cleanliness of the water compounds to be consumed by the villagers nearby later. Impractical management of oil and grease in water discharge would lead to long term deterioration of both environment and human health that sometimes lead to serious cases of human mortality and flora and fauna extinction.

Therefore, this study will determine the concentration of oil and grease in water discharge and nearby river in UMK Jeli. This information will be useful for people around the UMK Jeli and nearby residents about the level of oil and grease in water so that they can be more careful in consuming the water and also preventing the further pollution of the river from oil and grease.

1.3 Objectives

The objectives of this study are:

- i. To analyze the concentration of oil and grease in UMK Jeli cafeterias water discharge and nearby river.
- ii. To compare oil and grease concentration in water discharge from UMK Jeli cafeterias and nearby river with Environmental Quality Act (EQA) standard guideline.

1.4 Significance of Study

This study is being useful in updating the information about concentration of oil and grease in water discharge from UMK Jeli cafeterias. Collecting and gathering the data of water samples can help institution or authority to solve of oil and grease contamination in water discharged by not dumping cooking oil and grease into the kitchen sink or toilet bowl, using paper towels to wipe the remaining oil and grease from the pot and plates before washing them, and using grease trap in their drainage system. It could also aid future and present researcher with latest database of oil and grease.

The outcome from this study could really be the tools for the authority to start take action or as baseline data towards conserving the clean river and manage the water discharge in proper way especially at the institution and residential areas.

CHAPTER 2

LITERATURE REVIEW

2.1 Oil and Grease

An oil is a substances that are neutral, nonpolar chemical substance in a form of liquid at room temperatures and is both hydrophobic and lipophilic (El-Bestawy *et al.*, 2005). The oil contains high carbon and hydrogen which are flammable. The effects include accumulation of lighter oils in the wet wells of pumping stations, fouling of electrodes or float systems which leads to pump controls failures.

Where the nature of oil is highly flammable, it leads to explosion hazard in the treatment works (El-Bestawy *et al.*, 2005). Oil has a lot of functions but once the oil had been use, it will become contaminated and loss their original properties which end up as oily wastewater. There are several applications from the oils including for cooking, cosmetics, and fuels. Oil cannot be dissolved in water because they are less dense than water but they can be dissolved in organic solvent. Grease is an organic matter that insoluble in water and exist in form of solid or semi-solid at room temperature.

There are a few types of grease which are grease (lubricant) used as industrial lubricant, yellow grease and brown grease (Stenstrom *et al.*, 1986). The petroleum products and hydrogenated vegetable oil used as a replacement for animal fats. Grease in liquid form may not appear to be harmful but when it was disposed in the drain it will harden and form a blockage in the drainage system. This will lead to sewage flooding or else they will flow into the streams or river. Oil and grease can affect river, sediments, soil, sewage system and underground water. The oil and grease from the source of the

discharge will flow over into the nearby river or into sewage system. In some condition, it will be absorbed into the soil and go straight into the ground water. There are few sources of oil and grease which are from mill effluents, greywater from kitchen sink, food processing industries and so on. Oil mills comes from Palm Oil Mill Effluent (POME) may be categorized as an oily wastewater due to its high concentrations (4000 to 6000 mg/l) of oil and grease in water discharge (Ahmad *et al.*, 2005).

Besides Friedler (2004) reported that high concentration of oil and grease in domestic greywater and in all greyware streams was mainly from kitchen sink. The other source of oil and grease are from the food processing industries such as food packing factory and slaughter house.

Oil containing wastewater is also sourced from non-vegetable oil manufacturing industries such as the steel, machine, petroleum refining, metal cutting and metal forming, and textile industries (Wake, 2005). The presence of oil and grease in water will cause ecological damage such as increasing the BOD level and lower the DO level. This is because oil will form a layer in the surface of the water due it hydrophobic nature that will make the sun ray impossible to penetrate into the water. Next, similarly in the municipal water treatment plant, oil and grease cause objectionable taste and odors, turbidity and film, and make filtration treatment difficult (Alade *et al.*, 2011).

Substances like phenols and petroleum hydrocarbons, are toxic associated with fatty and oily wastewater which it can inhibit the growth of plant and animal, and causes carcinogenic to a human being (Lan *et al.*, 2009). Besides that, it may causes ecology damages for aquatic organisms if the oily wastewater are discharged in water body

(Islam *et al.*, 2013). The vegetable oil are classified as dangerous pollutants if it mixes with the aquatic ecosystem because it will become toxic to the aquatic organisms (Mendiola *et al.*, 1998).

2.2 Waste Water Effluent Discharge Standards.

Under the Environmental Quality Act 1974, the waste water effluent discharge standard are provided for both of standard A and standard B wastewater to limit the over discharged of contaminants in wastewater such as heavy metals, suspended solids, and oil and grease. Any industrial premises related that produced oily effluent whether into water or soil were applied this regulation as standard guideline to prevent further pollution of oil and grease towards environment. Table 2.1 shows the limits for water effluent according to EQA standard guideline used by Malaysia.

Table 2.1: Environmental Quality Act (EQA) standard guideline for water effluent.

Parameter	Unit	Standards	
		A	B
Temperature	°C	40	40
pH Value	-	6.0-9.0	5.5-9.0
BOD	mg/L	20	40
Oil and Grease	mg/L	1.0	10

2.3 Oily Water Discharge

Oil contaminated wastewater comes from variety of sources such as crude oil production, oil refinery, petrochemical industry, metal processing, compressor condensates, lubricant and cooling agents, car washing, restaurants (Lan *et al.*, 2009). These sources come from industries that consume oil and grease for their operation.

Wastewaters containing oil and grease, derived from vegetable oils, with a significant amount of linoleic acid have been reported to be challenging to treat due to the presence and concentration of linoleic, palmitic and myristic acids produced (Lalman & Bagley, 2000). Although oily water discharge are less toxic than gasses water discharge, an action should be taken to remove the oil and grease from water to prevent any bad effects.

2.4 Water Quality Standard

There are standards and criteria for which water quality should be maintained. There are certain requirements as regards suitability, industrial use, for drinking, for boilers and many more. The main aim of the standards is for the protection of the end uses by humans, animals, agriculture or industry. Water quality can be determined by physical, chemical and biological properties of water. For this study, National Water

Quality Standards for Malaysia was used as a guideline standards. Table 2.2 shows the National Water Quality Standards applied in Malaysia.

Table 2.2: National Water Quality Standards for Malaysia.

Parameter	Unit	Class					
		I	IIA	IIB	III	IV	V
BOD	mg/L	1	3	3	6	12	>12
COD	mg/L	10	25	25	50	100	>100
DO	mg/L	7	5–7	5–7	3–5	<3	<1
pH	-	6.5-8.5	6–9	6–9	5–9	5–9	-
Conductivity	µS/cm	1000	1000	-	-	6000	-
Temperature	°C	-	normal+2°C	-	normal+2°C	-	-
Turbidity	NTU	5	50	50	-	-	-
TDS	mg/L	500	1000	-	-	4000	-

2.4.1 Physico-Chemical Parameters

Physical characteristic of water such as temperature and turbidity are determined by senses of touch, sight, smell and taste. Some physical test ought to be performed for testing of its physical appearance, for example, temperature, colour, odour, pH, turbidity, TDS and so forth, while chemical tests should be performed for its BOD, COD, dissolved oxygen, alkalinity, hardness and other characters (Patil *et al.*, 2012).

This parameter is important to determine the safety of the water. A study of various physio-chemical parameters on the samples drawn from the river Koel, Shankha and Brahmani, India was operated and observed that dilution during rainy season decreases the metal concentration level to a considerable extent. However the enrichment of these metals by bio-magnification and bioaccumulation in edible elements produced in water is prove to produce a remarkable effect on the water of eep public

concern (Dey *et al.*, 2005). Other than that, a study of physico-chemical parameter was implemented in Hosahalli tank in Shimoga district, India monthly to analyze whether the water in the tank was polluted or not (Basavaraja *et al.*, 2011).

Based from the case study, it shows that physico-chemical parameter needed to be operated so that the pollution level of the water can be detected. Early prevention can be taken to reduce the negative impact of polluted water to humans and animals health.

a) Temperature

Water temperature is influenced via air temperature, storm water spillover, groundwater inflows, turbidity, and presentation to daylight. In considering the soundness of life forms, it is important to consider their most extreme temperature and ideal temperature. Excessive temperature changes can increase a chemical processes and can be lethal to both aquatic plants and wildlife (Wong *et al.*, 2013). The most extreme temperature is the most dangerous water temperature at which the creature will live for a couple of hours.

In a set up framework the water temperature controls the rate of every single compound response, and influences fish development, proliferation and safety. Extreme temperature changes can be deadly to fish (Patil *et al.*, 2012). So it is important to make sure the temperatures of the water are favourable for both aquatic plants and animals.

b) Conductivity

Conductivity have a connection with ten parameters, for example, temperature, pH, value, alkalinity, total hardness, calcium, total solids, total dissolve solids, chemical oxygen demand , chloride and iron in water (Patil *et al.*, 2012). This is a measure of the ability of a solution, for example, water in a stream to pass an electric flow.

c) Dissolved Oxygen

Dissolved oxygen will be oxygen gas atoms (O_2) present in the water. Plants and creatures can't straightforwardly utilize the oxygen that is a part of the water particle (H_2O). So they relying upon dissolved oxygen for breath. Oxygen enters streams from the air and as a result of photosynthesis from aquatic plants.

Reliably large amounts of dissolved oxygen are best for a safety biological community. Its relationship with water body gives direct and indirect data e.g. bacterial activity, photosynthesis, accessibility of nutrients, stratification and so on (Premlata, 2009).

d) Total Dissolve Solid (TDS)

Total dissolve solid can be defined as a measurement of salt that dissolve in the water without taking count of any suspended solid. The residue after any evaporation of water remained is also known as TDS.

e) Turbidity

Turbidity is a measure of how particles suspended in water influence water clarity. It is an essential pointer of suspended residue and disintegration levels. Commonly it will increment forcefully amid and after a precipitation, which causes residue to be conveyed into the creek. High turbidity will likewise raise water temperature, lower the level of dissolve oxygen, keep light from pass through to the aquatic plants which slowing up their capacity to photosynthesize, and hurt fish gills and eggs.

The utility of turbidity as a metric of microbial water quality stems from the suspicion that as the grouping of suspended particles, for example, clay and silt, increments in the water, so do the levels of microorganisms (Sarah *et al.*, 2010). How well the concentration of microorganisms in water may be associated with changes in the amount of bigger particles and changes in turbidity is exceedingly variable, depending on the conditions prompting the turbidity change (Gauthier *et al.*, 2003).

Turbidity in surface waters generally increases after rainfall (Atherholt *et al.*, 1998; Gauthier *et al.*, 2003).

f) pH

Solution's acidity can be measured by using pH. pH is measured on a logarithmic scale somewhere around 1 and 14 with 1 being too acidic, 7 neutral, and 14 being too basic. pH was emphatically connected with electrical conductance and complete alkalinity (Guptaa, 2009).

At the point when more hydroxide particles respond, more hydrogen particles are left and the water is acidic while at the point when more hydrogen particles respond, more hydroxide particles are left in arrangement and the water is basic. If pH is too high, it will causes a bitter taste while low pH water will corrode or dissolve metals due to its acidity. A pH range of 6.0-9.0 is vital for healthy ecosystems (Wong *et al.*, 2013). Sudden pH change often indicates chemical pollution (Li *et al.*, 2011). Thus, the pH level of water should be monitor to prevent further pollution. Figure 2.1 show the scale for the pH measurement.

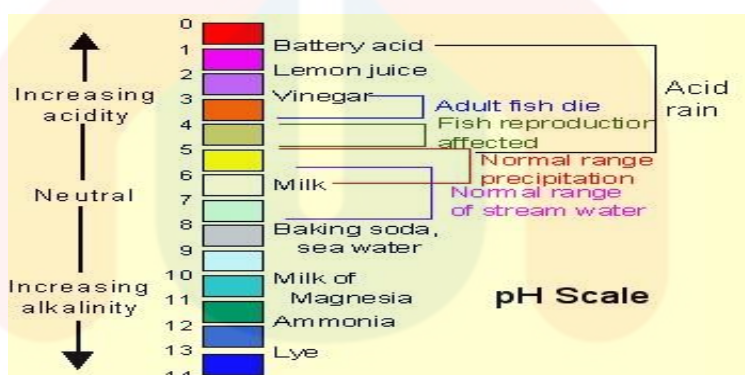

Figure 2.1: The pH scale (Elmhurst.edu, 2014)

g) Biochemical Oxygen Demand (BOD)

The determination of 5 day biochemical oxygen demand (BOD₅) is the institutionalized test to decide the relative oxygen prerequisites for watery organisms to expend natural materials in wastewaters, wastewater treatment plant (WWTP) profluent, or common waters (American Public Health Association, 2005).

BOD₅ has been utilized as a marker for the measure of natural poisons in most oceanic frameworks, particularly a decent marker for biodegradable natural mixes (Hur

and Kong, 2008). BOD is the measure of dissolve oxygen required for the biochemical deterioration of natural mixes and the oxidation of certain inorganic materials (e.g., iron, sulfites) (Patil *et al.*, 2012).



UNIVERSITI

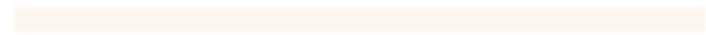

MALAYSIA



KELANTAN

CHAPTER 3

MATERIALS AND METHOD

3.1 Materials and Reagents

For the laboratory test, certain chemicals and apparatus are needed to operate the test. Method used in this study is called Hexane Extractable Gravimetric Method. Reagents such as hydrochloric acid solution 6.0 N, hexane ACS grade, sodium sulfate anhydrous, boiling chips silicon carbide and distilled water were used in this study.

Materials such as pH paper, adapter vacuum connector/gas inlet 28/15, aspirator vacuum pump, analytical balance, clamp 3 prong, clamp holder, clamp pinch type No. 28, F/glass joints, condenser reflux with ground glass joints 28/15, graduated cylinder 500 ml, graduated cylinder 50 ml, desiccator, filter funnel 65 mm short stem, filter paper, erlenmeyer flask 125 ml, erlenmeyer flask 125 ml with ground glass joint 28/15, separatory funnel 500 ml, drying oven, pipet filler safety bulb, serological pipet 5 ml, Ring support 4 inch, glass rod, steam bath, hot plate, stir bar, support ring stand, crucible tongs, connecting tube J shaped with ground glass joint 28/15 and tubing rubber were used in this study.

3.2 Sampling location

The samples were taken from drains of both UMK Jeli cafeterias which are Medan Selera ($5^{\circ}44'49.02''\text{N}$ $101^{\circ}51'44.78''\text{E}$), and IBS cafe ($5^{\circ}44'35.78''\text{N}$ $101^{\circ}51'56.15''\text{E}$) where the source of the oil and grease are discharged there. Other two

sampling points were from the nearby river located near to both cafeterias respectively which are Gemang River ($5^{\circ}44'35.29''\text{N}$ $101^{\circ}51'54.23''\text{E}$) and Lanas River ($5^{\circ}44'49.53''\text{N}$ $101^{\circ}51'44.88''\text{E}$). The samples from 4 different points were triplicate each and the average data were collected. Thus, there were 12 samples in a month. Then the samples were preserved with 6 ml of 1:1 hydrochloric acid solution and stored in the refrigerator.

Figure 3.1 shows the location of the sampling area. All the sampling points are located in Jeli, Kelantan. The water samples were collected once a month for 6 months starting May until October from 4 different sampling points. A selected physico-chemical parameters were taken during the sampling at the sampling sites and in the laboratory.



Figure 3.1: Map of Sampling Location.

3.3 Sample Collection and Storage

Samples were collected in wide-mouth glass bottles or directly in the separatory funnel for immediate analysis. The samples were collected directly in the separatory funnel thus, the determination of sample volume as follows.

- a. 350 mL of water were measured with a graduated cylinder.
- b. Water sample was poured into the separatory funnel.
- c. The laboratory pen were used to put a mark on the 350-mL level.
- d. The water sample was discarded and filled to this mark.

Water samples were preserved with 6 mL of 1:1 Hydrochloric Acid Solution for each liter or quart of sample for further analysis.

3.4 Preparation of Analysis Glass

The chips and distillation flask were cleaned with hot water and detergent. Then, rinsed it with distilled water followed by acetone or n-hexane. After that, the cleaned flask and boiling chips were put in a drying oven at 105–115 °C (220–240 °F) for 2 hours. Lastly, the temperature of the flask boiling chips were let decreased to room temperature by putting them in a desiccator for at least 30 minutes.

3.5 Distillation apparatus assembly

The distillation apparatus were set up as in Figure 3.2.

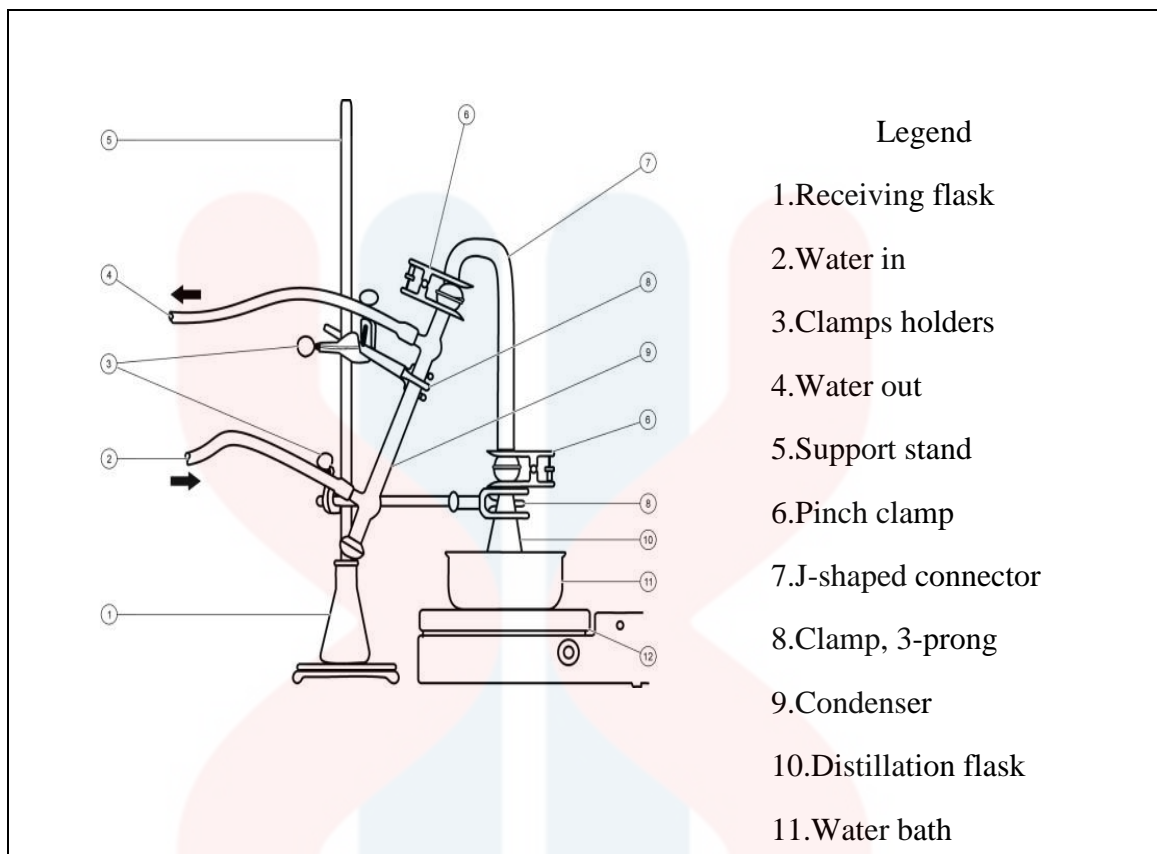

Figure 3.2: Distillation apparatus assembly

3.6 Test Procedure

3.6.1 Separation of Solvent and Water Layer

350 mL of water sample were collected in a clean 500 ml separatory funnel. A pipet and a pipet filler were used to add 4 mL of 1:1 Hydrochloric Acid solution to the separatory funnel. The solution was mixed.

A glass rod and a pH paper were used to measure the pH after the acid addition. During this laboratory, the clean and dry a 125 mL distillation flask that contains 3–5 boiling chips were used and weighted using analytical balance. The 20 mL of n-hexane were added to the separatory funnel. The gases were released through the stopcock. The

separatory funnel was shaken for 2 minutes vigorously. After that, the separatory funnel was put in the stand. The separatory funnel or the stand cannot be moved for a minimum of 10 minutes to letting the separation of the lower water layer and upper solvent layer.

3.6.2 Draining of Solvent and Water Layer

The lower water layer from the separatory funnel were slowly drained into the initial sample container or a 500 ml volumetric flask as shown on Figure A.1 in appendices A. Next, the glass funnel as put in the neck of the distillation flask. A folded 12.5 cm filter paper was being put in the funnel. Then, 10 g of anhydrous sodium sulfate were added to the filter paper. The sodium sulfate were being rinsed with a small amount of n-hexane and the n-hexane was discarded correctly.

The solvent layer were drained into the pre-weighed boiling flask through a funnel that contains filter paper and 10g anhydrous sodium sulfate. After that, by using glass rod, the sodium sulfate were stirred while the solvent layer drains. The water layer was returned to the separatory funnel. For the second and third extraction, the same glass funnel were used.

Then, the separatory funnel were rinsed with three different 5mL aliquots of fresh n-hexane to remove oil film that stayed on the funnel walls. Lastly, each aliquot was drained through the funnel that contains the sodium sulfate into the distillation flask.

3.6.3 Distillation of n-hexane.

The distillation assembly as shown in Figure 3.1 were used to distilled off the n-hexane. The distillation were done using rotary evaporator as showed in Figure A.3 in appendices A. A steam bath were used to keep a water bath at the correct temperature for the distillation. After 30 minutes, the condenser/connector portion of the distillation assembly were disconnected at the pinch clamp. Then, by using tongs the distillation flask were removed from the heat source.

The vacuum connector/gas inlet adapter were attached to remove the remaining solvent vapors from the distillation flask for until all n-hexane solvent vapors were removed. For 30 minutes, the flask was being put in a desiccator until the flask temperature was decreased to room temperature. The flask was cleaned again before each measurement to make sure that all contaminants were removed. Each weight were weighed and the lowest repeatable value were used for calculations. The flow for determination of oil and grease were showed in Figure 3.3.

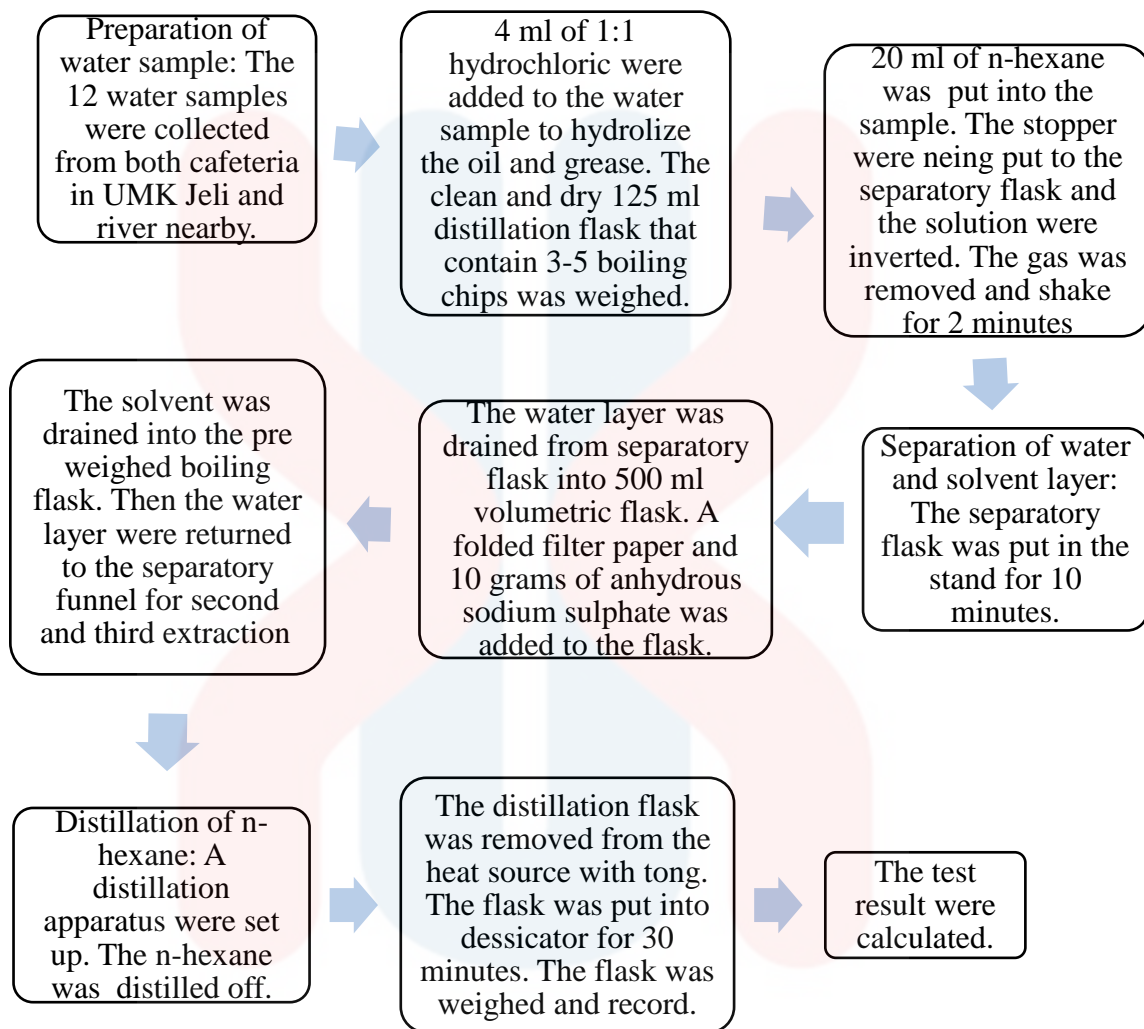

Figure 3.3: Analytical flow for determination of oil and grease.

3.7 Calculation

The test results were calculated using the formula below

$$[A - B] \div \text{Sample volume} \times 1000 = \text{mg/L HEM} \quad (\text{Eq. 3.1})$$

Where:

A = Weight (mg) of residue

B = Weight (mg) of flask with boiling chip

3.8 Water Quality Analysis

3.8.1 In-situ test

The physico-chemicals parameters were taken directly at the sampling point instead of performed it in laboratory. The selected parameters including temperature, conductivity, dissolved oxygen, total dissolved solid, turbidity and pH were taken at Gemang River and Lanang River using YSI multiparameter and turbidimeter as shown in Figure A.2 in appendices A. These parameters were measured using YSI 556 MPS Multi-parameter. Before the probe for in-situ measurement was dipped into the river, it was calibrated. The probe was partially dipped into the river for 10 minutes before the reading were recorded.

3.8.2 Ex-situ test

There were certain samples that need to be tested in the laboratory. These test were conducted to determine the BOD level in the Gemang River and Lanang River.

3.8.2.1 BOD test

First of all, the buffer solution was prepared by mixing one pack of pillow buffer with 3 L of distilled water in 5 L media bottle. The buffer solution were stored in

incubator at 20°C after being gently shaken to make sure that the solution completely dissolve.

For the BOD test, 10 ml of water sample were putted into the BOD bottle. Then, placed the buffer solution into the BOD bottle containing 10 ml of water samples until it reached the bottle mark. After that, the readings of initial DO (DO_1) were taken using BOD measurement package as showed in Figure A.4 in appendices A. All of the BOD bottle were sealed with aluminium foil and stored it in the incubator at 20°C for five days. Five days later, another DO measurement (DO_2), were taken.

CHAPTER 4

RESULT AND DISCUSSION

4.1 River Parameter

The various physicochemical parameters of sampling water from both Lanas River and Gemang River were analysed starting from May 2016 until October 2016 which are temperature, conductivity, Dissolve Oxygen (DO), Total Dissolve Solid (TDS), turbidity, pH and BOD taken using YSI multiparameter. The purpose of doing river parameters were to determine the condition of the river. Table 4.1 shows the data of physicochemical parameters in Lanas River and Gemang River.

Table 4.1: Physicochemical parameter in Lanas River and Gemang River

Parameter	Months												Mean	
	May		June		July		August		September		October		L	G
	L	G	L	G	L	G	L	G	L	G				
Temperature	30.01	30.08	32.23	29.27	29.7	29.74	29.34	29.28	30.21	30.18	26.66	26.32	29.69	29.15
Conductivity	103.00	83.00	107.00	83.00	96.00	46.00	87.00	44.00	104.00	78.00	105.00	65.00	100.30	66.50
DO	3.59	6.42	4.84	7.33	6.22	8.97	7.09	7.84	6.74	7.01	4.17	5.00	5.44	7.10
TDS	61.00	49.00	67.00	29.00	55.00	28.00	53.00	27.00	67.00	61.00	66.00	53.00	61.50	41.17
Turbidity	2.08	4.01	2.33	2.28	2.29	2.29	4.43	5.94	2.12	2.12	5.34	8.75	3.10	4.23
pH	6.79	7.44	6.94	7.72	7.39	7.41	7.58	7.64	6.93	6.74	6.60	6.69	7.04	7.27
BOD	5.40	1.20	15.20	4.20	7.50	1.50	16.80	2.40	5.70	1.50	14.10	10.80	10.80	3.60

L=Lanas River

G=Gemang River



4.1.1 Temperature

The Figure 4.1 shows the graph of monthly temperature for Lanas River and Gemang River. Based on the Table 4.1 an Figure 4.1, the highest temperature was taken in June 2016 with the value of 32.23°C from the Lanas River while the lowest temperature are taken from in October 2016 with the value of 26.32°C. The condition of high temperature during June 2016 are because of the drought season occurring from February to end of June in 2016. The high temperature in Lanas River can be the cause of the low amount of DO in the river based on the data from Figure 4.1. The high temperature can speeded up some reaction in the river and reduce the solubility of oxygen (Singh *et al.*, 2011). The temperature of Gemang River in October is the lowest. This can caused by the surrounding of the Gemang River that is surrounded by plants.

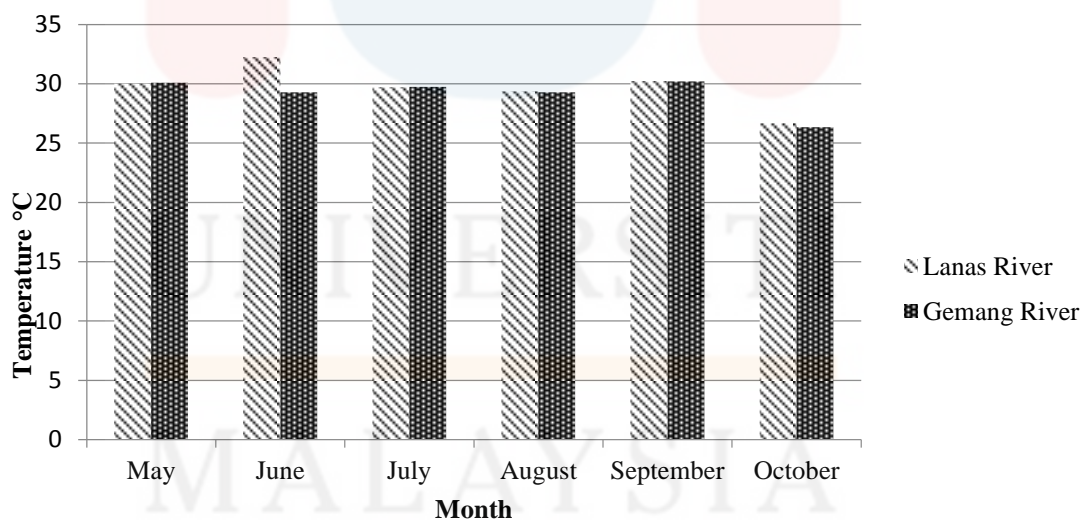

Figure 4.1: The temperature of Lanas River and Gemang River from May to October 2016.

4.1.2 Conductivity

Figure 4.2 shows the graph of monthly conductivity for Lanas River and Gemang River. The highest values of conductivity was on June 2016 in Lanas River with the value of 107.00 $\mu\text{S}/\text{cm}$ based on Table 4.1 while the lowest conductivity was recorded on August with the value of 44.00 $\mu\text{S}/\text{cm}$ based on Table 4.1 in Gemang River compared with other conductivity values from the other months. The value of the conductivity are depends on certain factors including the temperature of the surrounding during the reading was taken. The temperature recorded on August at Gemang River were 29.28°C while on June, the temperature for Lanas River were 32.23°C. That indicates the surrounding was quite hot to affect the increasing rate of conductivity in Lanas River. If the conductivity is high, it indicates the presence of high dissolved salt such as chloride, sulfate, sodium, calcium and others sources. Increases in this dissolved salt may affect the living aquatic organism (Li *et al.*, 2011).

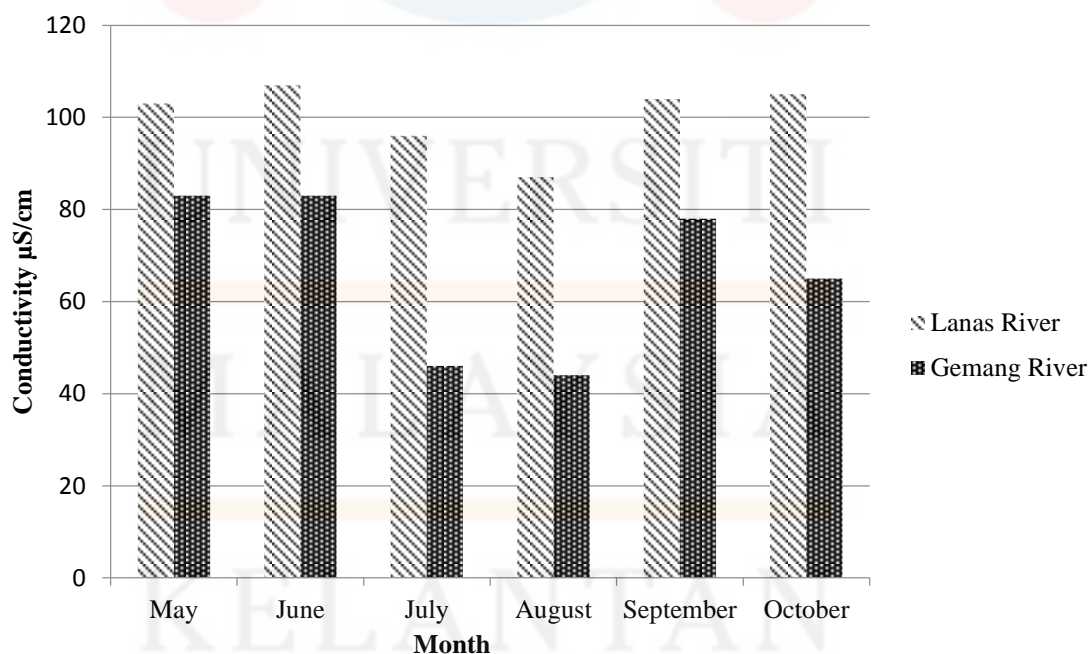

Figure 4.2: The conductivity of Lanas River and Gemang River from May to October 2016.

4.1.3 Dissolve Oxygen (DO)

DO can be used to measure the degree of pollution by organic matter, the destruction of organic substances and also as the self purification capacity of the water body (Singh *et al.*, 2012). Based on the Figure 4.3, the highest DO value was taken on July in Gemang River which are 8.97 mg/l based on Table 4.1, while the lowest DO value was recorded on May in Lanas River with the value of 3.59 mg/l based on Table 4.1. During July, the cafeteria for both Medan Selera and IBS cafe were closed due to the semester break. So the levels of pollutions are decrease causing the DO level to be increased. Moreover, the higher the temperature of the river, the lower the the level of the dissolved oxygen.

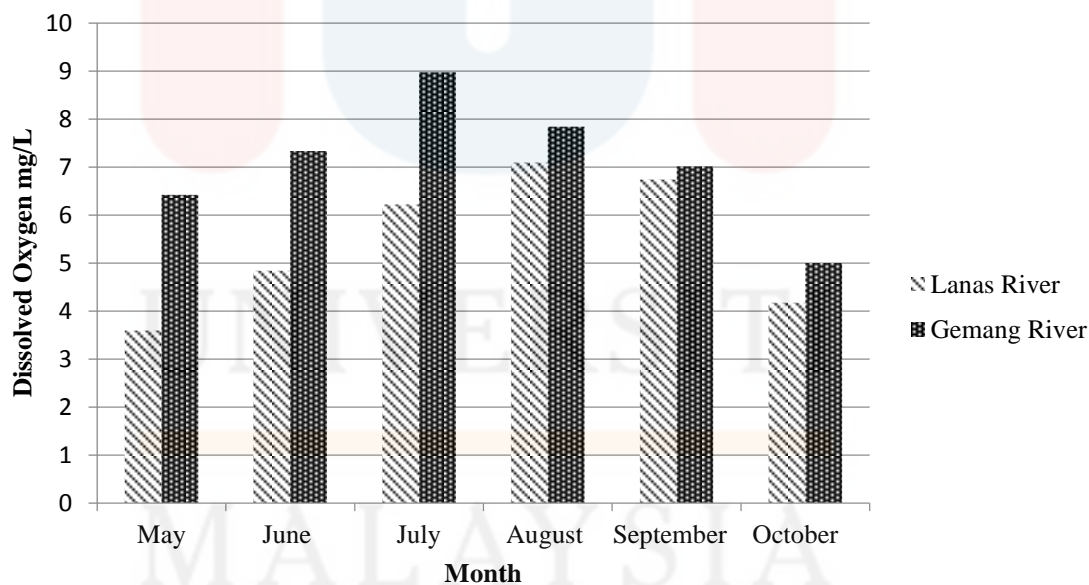

Figure 4.3: The Disolved Oxygen of Lanas River and Gemang River from May to October 2016.

4.1.4 Total Dissolve Solid (TDS)

Based on the Figure 4.4, the Total Dissolve Solid (TDS) during September and June 67.00 mg/l from Lanas River was the highest among all TDS in other months while the lowest TDS was on August with the value of 27.00mg/l from Gemang river. The amount of TDS in Lanas River is more higher than Gemang River due to the fact that along the Lanas River, there are also other food premises nearby. The premises also releasing a discharged water into the Lanas River. The parameters of conductivity, pH and temperature will affected the TDS level in water.

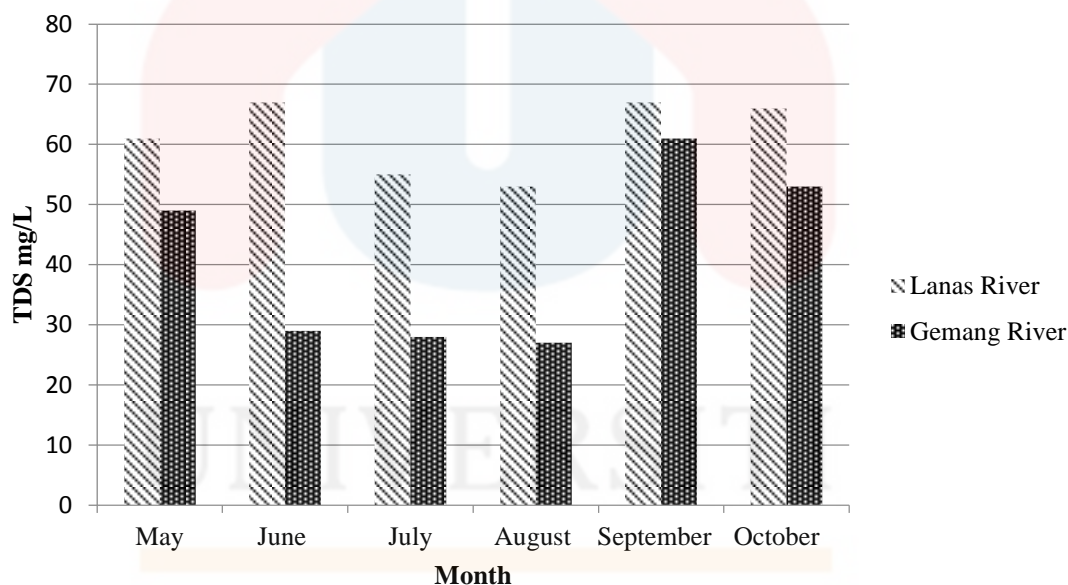

Figure 4.4: The TDS of Lanas River and Gemang River from May to October 2016.

MALAYSIA
KELANTAN

4.1.5 Turbidity

Figure 4.5 shows the graph of monthly turbidity in both Lanas River and Gemang River. The highest turbidity amount recorded was during October in Gemang River with the value of 8.57 NTU while the lowest turbidity was on May 2.08 NTU from Lanas River. The Gemang River has the high value of turbidity on October because the day before the sampling event, a heavy rains were happening causing the flow of the water increased thus, the turbidity also increase. The soil around the Gemang River will slide into the river thus, make the river become muddy. Turbidity are caused by phytoplankton or by sediments suspended in water. Water that is high in sediments are brown in colour (Wong *et al.*, 2013)

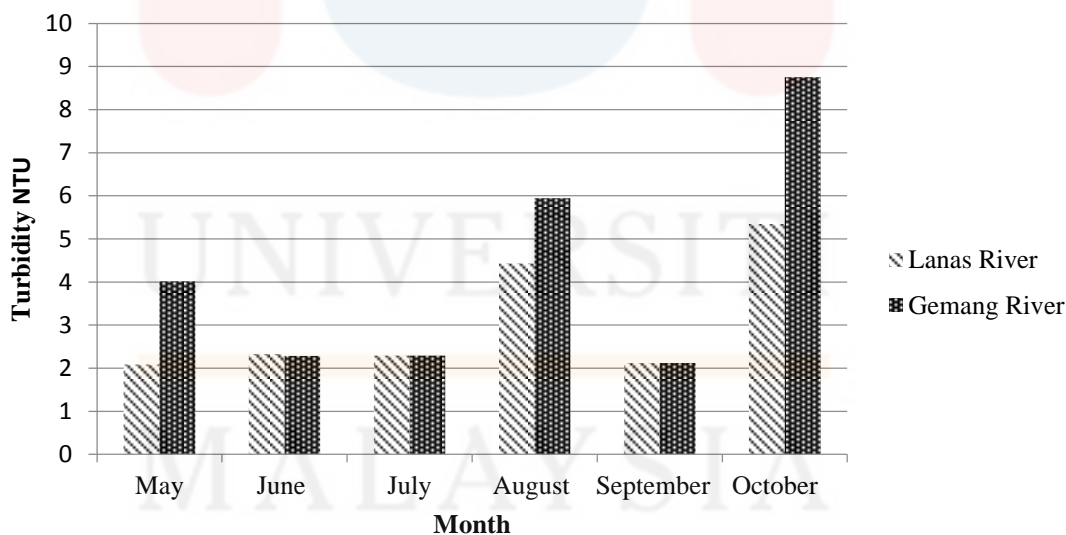

Figure 4.5: The turbidity of Lanas River and Gemang River from May to October 2016.

4.1.6 Biological Oxygen Demand (BOD)

Figure 4.6 shows the graph of monthly BOD for both Lanas River and Gemang River. BOD is the measure of the oxygen required by microorganisms FOR breaking down the organic matter (Singh *et al.*, 2012). The highest Biological Oxygen Demand (BOD) was recorded in August with the value of 16.8 mg/l in Lanas River while the lowest BOD was taken in May 1.20 mg/l for in Gemang River. The high amount of BOD level indicates that the river is not clean. Thus, the most lowest value of BOD indicates the cleanest river which is Gemang River compared to Lanas River. However the value of the BOD for both river do not exceeded the limits of BOD value according to Environmental Quality Act (EQA) for standard B water, which is 40 mg/l. The BOD was calculated by using formula of $(DO_1 - DO_2) \times \text{dilution factor}$.

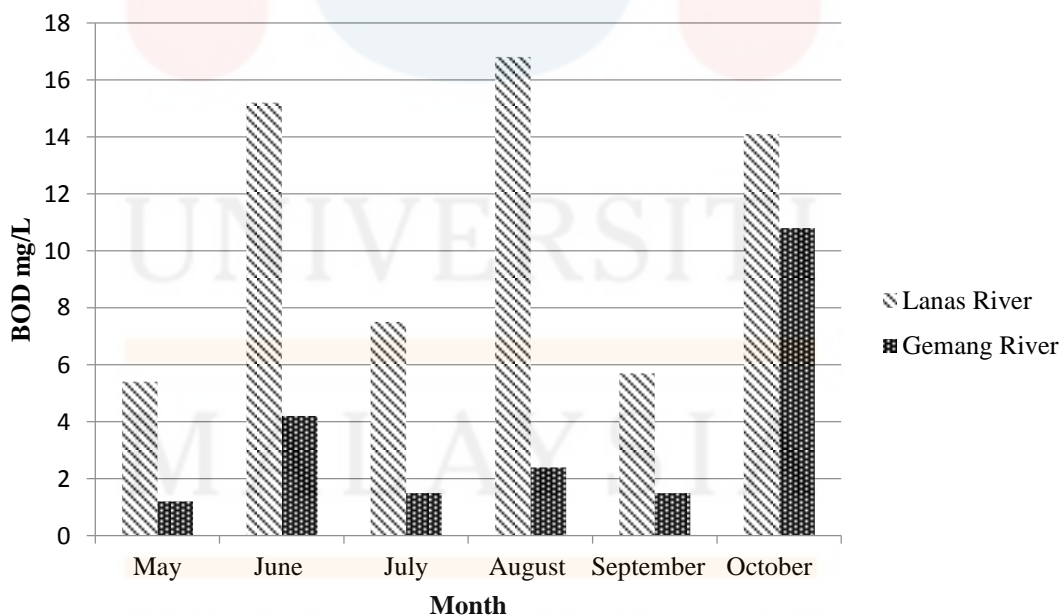

Figure 4.6: The BOD of Lanas River and Gemang River from May to October 2016.

4.2 Oil and Grease

Table 4.2 shows the total oil and grease collected monthly in four differences station which are Lanas River, Medan Selera, Gemang River and IBS cafe.

Table 4.2: The total oil and grease collected mg/L

Months	The Total oil and grease collected Mg/L			
	Lanas River (A1)	Medan selera (A2)	Gemang River (B1)	IBS cafe (B2)
May	2.48	3.72	0.57	1.61
June	2.1	3.81	1.71	1.24
July	0.38	0.86	0.19	0
August	1.43	1.62	0	0
September	2.09	4.95	0.95	2.3
October	2.19	4.01	0.76	3.24

Figure 4.7 shows the graph of month against total oil and grease collected of the oil and grease collected from four different stations in University Malaysia Kelantan within six months.

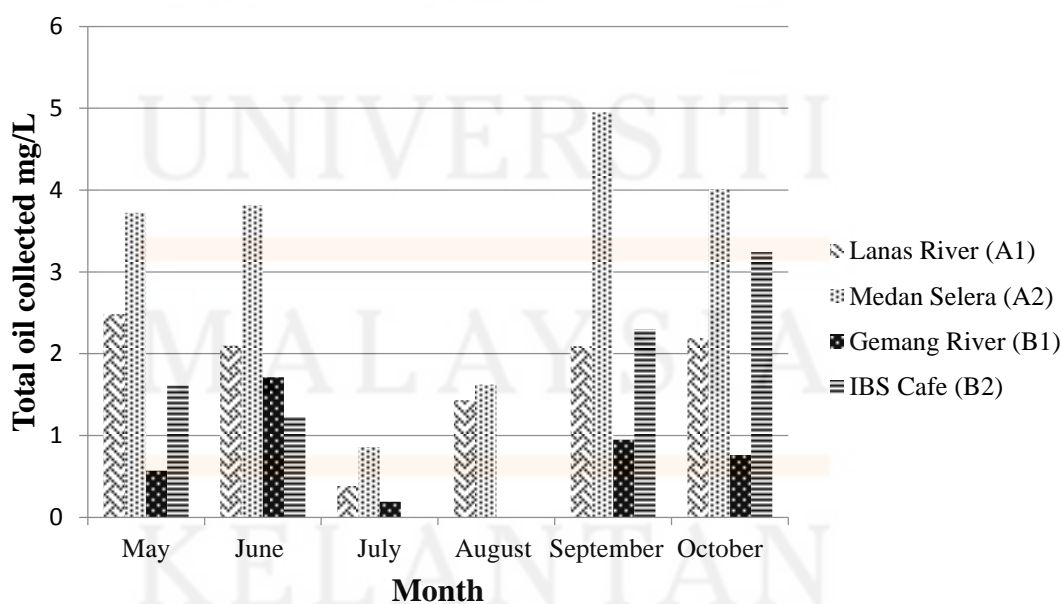

Figure 4.7: Graph of monthly oil collected

The total oil and grease collected are calculated using formula of oil and grease HEM formula .From the Figure 4.7, the highest concentration of oil and grease in May was Medan Selera followed by Lanas River, IBS Cafe and Gemang River. Lanas River has the amount of oil and grease higher than IBS Cafe and Gemang River because the high concentration of oil and grease from Medan Selera are flowing into the Lanas River. The oil and grease in water discharge from the Medan Selera will flow into the nearby river which is the Lanas River.

The factors that contributed to the high amount of oil and grease in water discharged and Lanas River is due to the operational time and activity from the Medan Selera operating almost every day. However the oil and grease collected are not exceeding the limits of EQA guidelines for water effluent for standard B which is 10 mg/l.

On June, the highest concentration of oil and grease was Medan Selera, Lanas River, Gemang River and Gemang River. The amount obtained for the oil and grease in Gemang River was higher than IBS Cafe because oil and grease from other difference resources such as nearby residence are also contain in the Gemang River.

Figure 4.7 shows that on July, the highest amount of oil and grease was taken from Medan Selera followed by Lanas River, Gemang River and IBS Cafe. Both Cafeteria are not operational during this month because all of the students were on their semester break. The IBS Cafe drain were not containing any water discharged. Thus, the experiment to determine the concentration of oil and grease cannot be proceeded for IBS

Cafe. That was the reasons why the concentration of oil and grease for IBS Cafe were zero.

However, the concentration of oil and grease in Gemang River still can be determined as the river still contained oil and grease from other resources. The oil and grease are still can be detected in both Lanang River and the water discharged of Medan Selera because the drainage system of Medan Selera are quite clogged with soil around it. So the water is remain stagnant and containing a few oil and grease in it. When it is raining, the water discharged will flow into the Lanang River.

On August the highest concentration of oil and grease based on Figure 4.7 was Medan Selera followed by Lanang River, IBS Cafe and Gemang River. Both cafeterias were still closed and do not operate yet causing the drain of IBS Cafeteria still dry from water discharged thus, resulting in zero concentration of oil and grease. In September, the figure 4.7 shows that the highest concentration of oil and grease is taken from Medan Selera followed by Lanang River, IBS Cafe and Gemang River while in October, the highest amount of oil and grease is Medan Selera followed by Lanang River, IBS Cafe and Gemang River.

4.3 Comparison with EQA Standard Guideline

Table 4.3 shows the comparison of oil and grease in Lanang River, Medan Selera, Gemang River and IBS Cafe with EQA Standard Guideline of oil and grease standard B.

Table 4.3: Comparisons of oil and grease with EQA Standards

Month	Comparisons of oil and grease with EQA Standards mg/L							
	Lanas River	EQA	Medan Selera	EQA	Gemang River	EQA	IBS café	EQA
May	2.48	10	3.72	10	0.57	10	1.61	10
June	2.1	10	3.81	10	1.71	10	1.24	10
July	0.38	10	0.86	10	0.19	10	0	10
August	1.43	10	1.62	10	0	10	0	10
September	2.09	10	4.95	10	0.95	10	2.3	10
October	2.19	10	4.01	10	0.76	10	3.24	10

It is a mandatory for wastewater in urban areas and townships to be treated before discharged into surface waters. The quality of effluent is regulated by the Environmental Quality Act 1974 (Department of Health, 2011). The wastewater that are discharged into the river must be treated first. The dominant wastewater treatment types are preliminary (removal of rags, rubbish, grit, oil, grease), primary (removal of settleable and floatable materials), and secondary treatment (biological treatment to remove organic and suspended solids) (Indah Water Konsortium, 2011).

Based from the Table 4.3, oil and grease collected from Medan Selera which are 3.72 mg/l, 3.81 mg/l, 0.86 mg/l, 1.62 mg/l, 4.95 mg/l and 4.01 mg/l for May, June, July, August, September and October respectively, the amount of oil and grease contained in the water discharged are below the standard of EQA standard guideline which is 10 mg/l for standard B. Figure 4.8 shows that the amount of oil and grease in Medan Selera within six month do not exceeding the standards given by EQA.

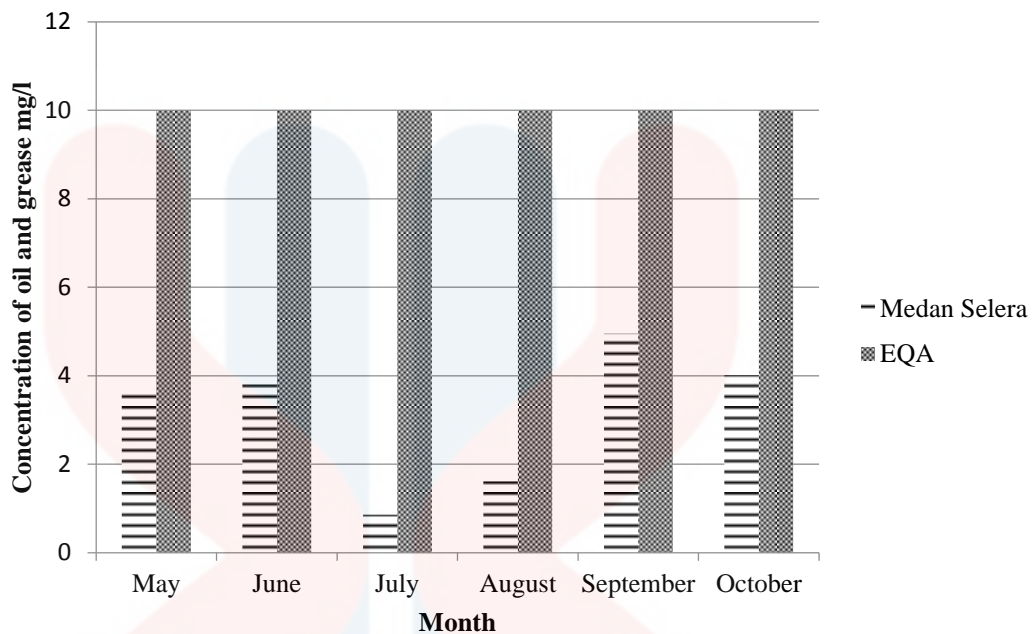

Figure 4.8: Graph of EQA standard comparison with Medan Selera

Based from the Table 4.3, the amount of oil and grease contained in wastewater from IBS cafe are 1.61 mg/l, 1.24 mg/l, 0 mg/l, 0 mg/l, 2.30 mg/l and 3.24 mg/l in May, June, July, August, September and October respectively. The amount of oil and grease in water discharged from IBS cafe are also below the standard EQA guideline for water effluent standard B. Figure 4.9 shows that the amount of oil and grease in Medan Selera within six month do not exceeding the standards given by EQA.

UNIVERSITI
MALAYSIA
KELANTAN

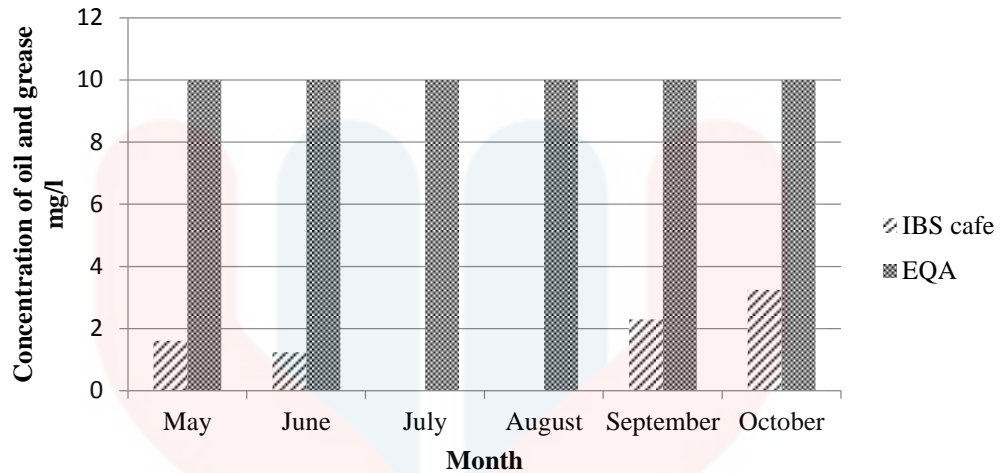

Figure 4.9: Graph of EQA standard comparison with IBS Cafe

Based from the Table 4.3, oil and grease collected from Lanas River which are 2.48 mg/l, 2.10 mg/l, 0.38 mg/l, 1.43 mg/l, 2.09 mg/l and 2.19 mg/l for May, June, July, August, September and October respectively, the amount of oil and grease contained in the water discharged are below the standard of EQA standard guideline which is 10 mg/l for standard B. Figure 4.10 shows that the amount of oil and grease in Medan Selera within six month do not exceeding the standards given by EQA.

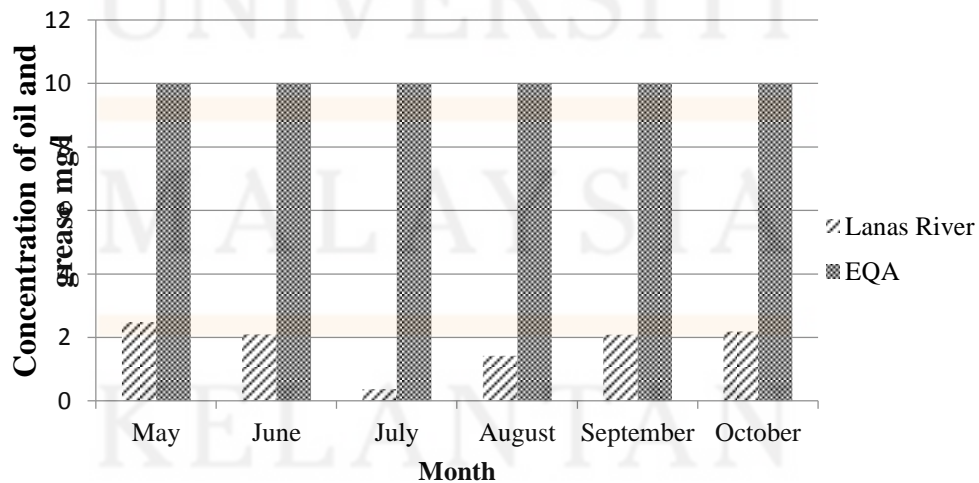

Figure 4.10: Graph of EQA standard comparison with Medan Selera

Based from the Table 4.3, oil and grease collected from Gemang River which are 0.57 mg/l, 1.71 mg/l, 0.19 mg/l, 0 mg/l, 0.95 mg/l and 0.76 mg/l for May, June, July, August, September and October respectively, the amount of oil and grease contained in the water discharged are below the standard of EQA standard guideline which is 10 mg/l for standard B. Figure 4.11 shows that the amount of oil and grease in Medan Selera within six month do not exceeding the standards given by EQA.

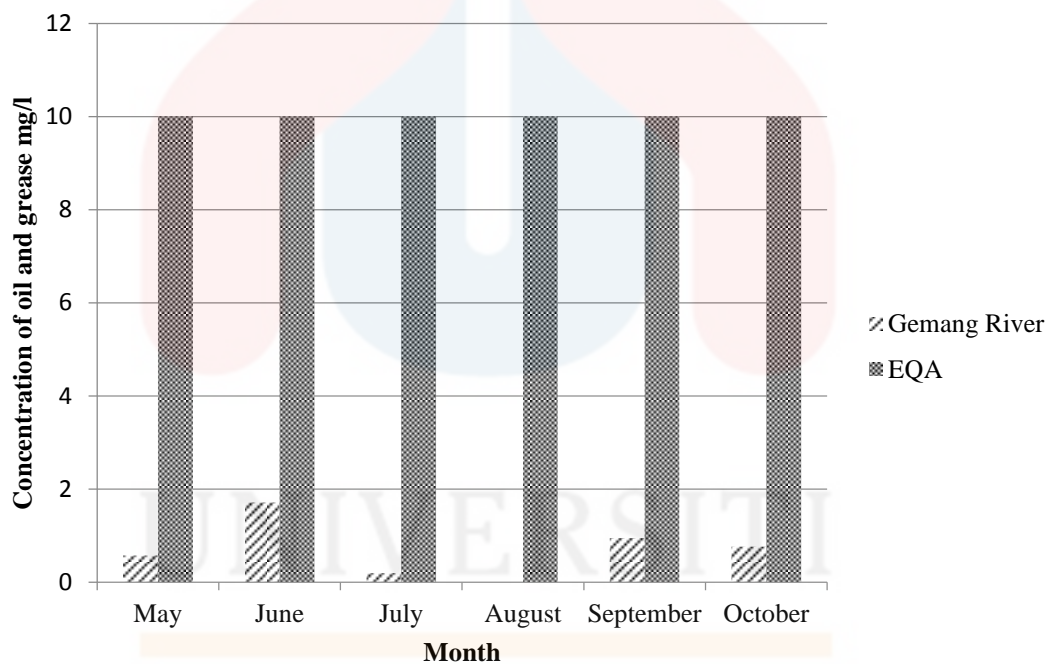

Figure 4.11: Graph of EQA standard comparison with Gemang River

MALAYSIA
KELANTAN

CHAPTER 5

CONCLUSION & RECOMMENDATION

5.1 Conclusion

In this research, the study of determination of oil and grease in water discharge by using Hexane Extractable Material method had been carried out. The result were obtained by calculating the amount of oil and grease in waste water using a formula. A few physicochemical parameters had been carried out too such as temperature, conductivity, DO, TDS, turbidity, pH and BOD.

From the results of oil and grease determination, the highest amount of oil and grease content in water discharged was obtained from Medan Selera with the average of 3.16 mg/l oil and grease followed by Sungai Lanas 1.78 mg/l, IBS cafe 1.40 mg/l and Gemang River. From this data, it can be said that among all of the sampling points, the average of oil and grease concentration are mostly high in Medan Selera water discharge. These findings conclude that the first objective of this study which is to analyze the concentration of oil and grease UMK Jeli cafeterias water discharge and nearby river was achieved.

The concentration of oil and grease obtained from four sampling point which are Lanas River (point A1), Medan Selera (A2), Gemang River (B1) and IBS cafe (B2) then will be compared with the EQA standard guideline for water effluent standard B water. From the comparison, all of the sampling point are below the standard fixed by the EQA,

10 mg/l. This means that the water discharged from both cafeteria in UMK Jeli can be released into the river nearby without being treated first. The second objective of this study which is to compare oil and grease concentration in water discharge from UMK Jeli cafeterias and nearby river with Environmental Quality Act (EQA) standard guideline were achieved.

5.2 Recommendation for Future Research

This research was able to determine the concentration of oil and grease in water discharged from UMK Jeli cafeteria and nearby river. it can be concluded that the higher concentration of oil and grease was obtained from Medan Selera water discharge due to the fact that Medan Selera is the source of oil and grease. However, there are a few recommendations that can be taken into consideration for better understanding and accurate result in future research.

Firstly, during handling the n-hexane, do not proceed the experiment near the windows as the the n-hexane are easily volatile. This will reduce the volume of the n-hexane and might be insufficient to be used in the experiment. It should be handle in the fume chamber.

Secondly, is to know the number population of residents that living nearby the Gemang and Lanang River so that we can identify the various resources of oil and grease in both rivers beside the umk cafeteria.

Last but not least is to add another method in oil and grease recovery in wastewater for this study. There are many types of oil and grease recovery method. With

this additional method, the concentration of oil and grease in water discharged can be reduced. Student also will be more practical in applying sustainable practices with the knowledge.



UNIVERSITI

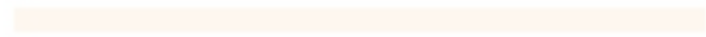

MALAYSIA

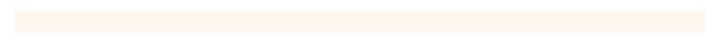

KELANTAN

REFERENCES

- Ahmad, A. L., Bhatia, S., Ibrahim, N. & Sumathi, S. (2005). Adsorption of Residual Oil from PalmOil Mill Effluent Using Rubber Powder. *Brazilian Journal of Chemical Engineering* 22(3): 371-379.
- Alade, A. O., Jameel, A. T., Muyubi, S. A., Abdul Karim, M. I. & Zahangir, MD. Z. (2011). Removal of oil and grease as emerging pollutants of concern (EPC) in wastewater stream. *IIUM Engineering Journal* 12(4): 161-169.
- American Public Health Association, American Water Works Association, & Water Environment Federation. (2005). *Standard Methods For the Examination of Water and Wastewater* 21, American Public Health Association
- Atherholt, T., LeChevallier, M., Norton, W. & Rosen, J. (1998). Effect of rainfall on Giardia and crypto. *J Am Water Works Assoc* 90: 66–80.
- Dey, Kallol, Mohapatra, S. C., Misra, Bidyabati. (2005). Assessment of water quality parameters of the river Brahmani at Rourkela. *Journal of Industrial Pollution Control* 21(2): 265-270.
- El-Bestawy, E., El-Masry, M. H. & El-Adl, N. E. (2005). The potentiality of free Gramnegative bacteria for removing oil and grease from contaminated industrial effluents. *World Journal of Microbiology & Biotechnology* 21: 815–822.
- Elmhurst. Edu, (2014). Ph Scale. [online] Available at: <http://www.elmhurst.edu/~chm/vchembook/184ph.html> [Accessed 15 May. 2014]
- Gauthier, V., Barbeau, B., Tremblay, G., Millette, R. & Bernier, A. (2003). Impact of raw water turbidity fluctuations on drinking water quality in a distribution system. *J Environ Eng Sci* 2: 281–297.
- Gupta, D. P., Sunita & Saharan, J. P., (2009). Physiochemical Analysis of Ground Water of Selected Area of Kaithal City (Haryana) India. *Researcher* 1(2): 1-5.
- Hur, J. & Kong, D. S. (2008). Use of synchronous fluorescence spectra to estimate biochemical oxygen demand (BOD) of urban rivers affected by treated sewage. *Environmental Technology* 29(4): 435–444.
- Isehunwa, S. O. & Onovae, S. (2011). Evaluation of produced water discharge in the Niger-Delta. *Journal of Engineering and Applied Sciences* 6(8): 66-72.

- Islam, M. S., Saiful, M., Hossain, M., Sikder, M., Morshed, M., Hossain, M. (2013). Acute toxicity of the mixtures of grease and engine wash oil on fish, pangasiussutch, under laboratory condition. *International Journal Life Science, Biotechnology and Pharmacology Research*. 2(1): 306–317.
- Lalman, J. A. & Bagley. D. M. (2000). Anaerobic degradation and inhibitory effects of linoleic acid. *Water Res* 34(17): 4220–4228.
- Lan, W. U., Gang, G. E. & Jinbao, W. A. N. (2009). Biodegradation of oil wastewater by free and immobilized *Yarrowia lipolytica* W29. *Journal of Environmental Sciences* 21: 237–242.
- Li, Y., Zhou, M., & Zhao, J. (2011) Laboratory Qualifications for Water Quality Monitoring, Water Quality Concepts, Sampling, and Analysis. USA. *CRC Press* 7: 137-156
- Mendiola, S., Achutegui, J.J., Sanchez, F.J. & San, M.J. (1998). Polluting potential wastewater from fish-meal and oil industries. *GrasaAceites* 49: 30–33
- Patil, P. N., Sawant, D.V., Deshmukh, R. N. (2012). Physico-chemical parameters for testing of water – A review. *International Journal of Environmental Sciences* 3(3): 1194-1207.
- Premlata, Vikal, (2009). Multivariant analysis of drinking water quality parameters of lake Pichhola in Udaipur, India. *Biological Forum, Biological Forum- An International Journal* 1(2): 97-102.
- Basavaraja, S., Hiremath, S. M., Murthy, K. N. S., Chandrashekarappa, K. S., Anil, N. P., Puttiah, E. T. (2011). Analysis of Water Quality Using Physico-Chemical Parameters Hosahalli Tank in Shimoga District, Karnataka, India. *Global Journal of Science Frontier Research* 11(3): 31-34.
- Sarah, C. T., Christine, L. M., Mitchel, K., Dana, W. F., Jim, U., Appiah, A., Philip S. & Paige, E. T. (2010). Drinking water turbidity and emergency department visits for gastrointestinal illness in Atlanta, 1993–2004. *Journal of Exposure Science and Environmental Epidemiology* 20: 19-28.
- Singh, S. N., Srivastav, G. & Bhatt, A. (2012). Physicochemical Determination of Pollutants in Wastewater in Dheradun. *Current World Environment* 7(1): 133-138.
- Stenstrom, M. K., Fam, S. & Silverman, G. S. (1986). Analytical methods for quantitative and qualitative determination of hydrocarbons and oil and grease in water and wastewater. *Environmental Technology letters* 7(3): 625-636.

Wake, H. (2005). Oil refineries: A review of their ecological impact on the aquatic environment, Estuarine, Coastal and Shelf. *Journal Science* 62: 131-140.

Wong, Y. C., Moganaragi V., Atiqah N. A. (2013). Physico-chemical Investigation of Semiconductor Industrial Wastewater. *Oriental journal of chemistry* 29(4): 1421-1428.



APPENDICES A



Figure A.1 Separation of oil and water



Figure A.2 YSI multiparameter and turbidimeter



Figure A.3 Rotary evaporator



Figure A.4 BOD Measurement Package

MALAYSIA
UNIVERSITI
KELANTAN